

# ERGOADVANTAGE™

BY APPLIED ERGONOMICS

ELECTRIC HEIGHT ADJUSTABLE TABLE



## DIRECTIONS FOR USE / ASSEMBLING

EN



**WARNING**

**WARNING:** FAILURE TO COMPLY WITH OR OBSERVE ALL ASSEMBLY, SAFETY AND OPERATION INSTRUCTIONS AND WARNINGS REGARDING THE USE OF THIS PRODUCT MAY RESULT IN SERIOUS BODILY INJURY.

### IMPORTANT NOTES!

Prior to installment, use and maintenance of the table frame, any installer and any user of the table must study this assembly and operation manual carefully, so as to gain a complete understanding of its contents.

# ERGO ADVANTAGE™

BY APPLIED ERGONOMICS

## Regular Desktop Sizing



**24"x 36"**



**24" x 42"**



**30" X 36"**



**30" x 42"**

## TABLE OF CONTENT

1. SAFETY AND WARNINGS
2. USAGE
3. SET UP AND INSTALLATION
4. OPERATION
5. MAINTENANCE AND DEFECTS
6. TECHNICAL DATA
7. PARTS
8. ASSEMBLY DIRECTIONS
9. DECLARATION OF CONFORMITY

### 1. SAFETY AND WARNINGS

- This table complies with the prescribed safety regulations. Inappropriate use may cause damage to persons and table.
- Please read the operation manual prior to start using the table. It provides you with important information about safety, use, installation and maintenance of the table, and thus protecting you and your children and avoiding damage on the table.
- Please guard this operation manual and pass it on to any future owner!

### 2. USAGE

- The electromotive, height-adjustable tables are designed for workstations in dry work environments only. The table height is infinitely adjustable, so that it can be set to the most ergonomically suitable working level.
- They have not been designed for other purposes than those included in this manual, e.g. they are not to be used in areas of high humidity or dampness, nor for lifting people. Any other use is at one's own risk!
- **Do not crawl, lie or move around under the table frame, and do not sit or stand on the table frame.**
- **CHILDREN should only use the table when supervised by adults.**
- **Liability:** The manufacturer accepts under no circumstances warranty claims or liability claims for damages arising from improper use or handling of the table frame other than that described in this operation manual.

### 3. SET UP AND INSTALLATION

When the table has been assembled (see assembly instructions chapter 8) the adjustable feet are installed so that the table is level and does not shift. Then the table is connected to the 110-230 VAC outlet and the table is ready for use.

- Make sure that no cables can get jammed.
- Place the table in a safe distance from window frames, radiators, furniture etc. so that people do not get stuck.
- Do not place any objects above 55 cm underneath the table.
- When moving the table after it has been assembled, the table top needs to be removed. The table CANNOT be lifted by the tabletop.

### 4. OPERATION

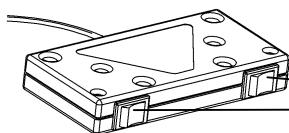

**UP/DOWN operation:**  
BOTH buttons must be pressed SIMULTANEOUSLY either right or left.

## 5. MAINTENANCE AND DEFECTS

- The table does not require any maintenance by usage as described in chapter 2 in the directions for use.
- The table is only to be maintained with a wrung cloth.
- In the event of the occurrence of jarring sounds during operation, STOP using the table and please contact the dealer.

## 6. TECHNICAL DATA

<b>Frame, materials and weights:</b>	Steel, silver - Weight metal frame ~ 30 kg
<b>W</b>	60-160 cm
<b>D</b>	50-100 cm
<b>H</b>	68 – 120 cm
<b>V (speed)</b>	~28 mm/sek.
<b>F<sub>MAX</sub></b> = Max. Load on tabletop: 	120 kg
<b>Operation:</b>	Rocker switches
<b>Voltage:</b>	220-230 VAC / 50Hz or 110-100 VAC / 60Hz
<b>Consumption:</b>	80 Watt

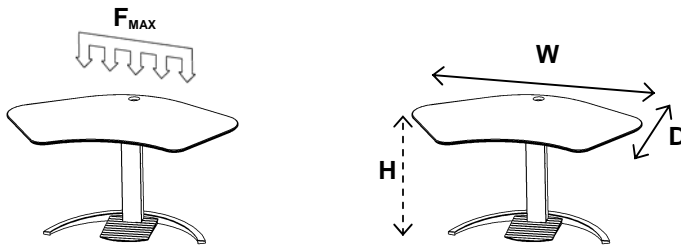

## 7. PARTS (containing 2a, 2b or 2c and 3a or 3b, assembly is similar on all)

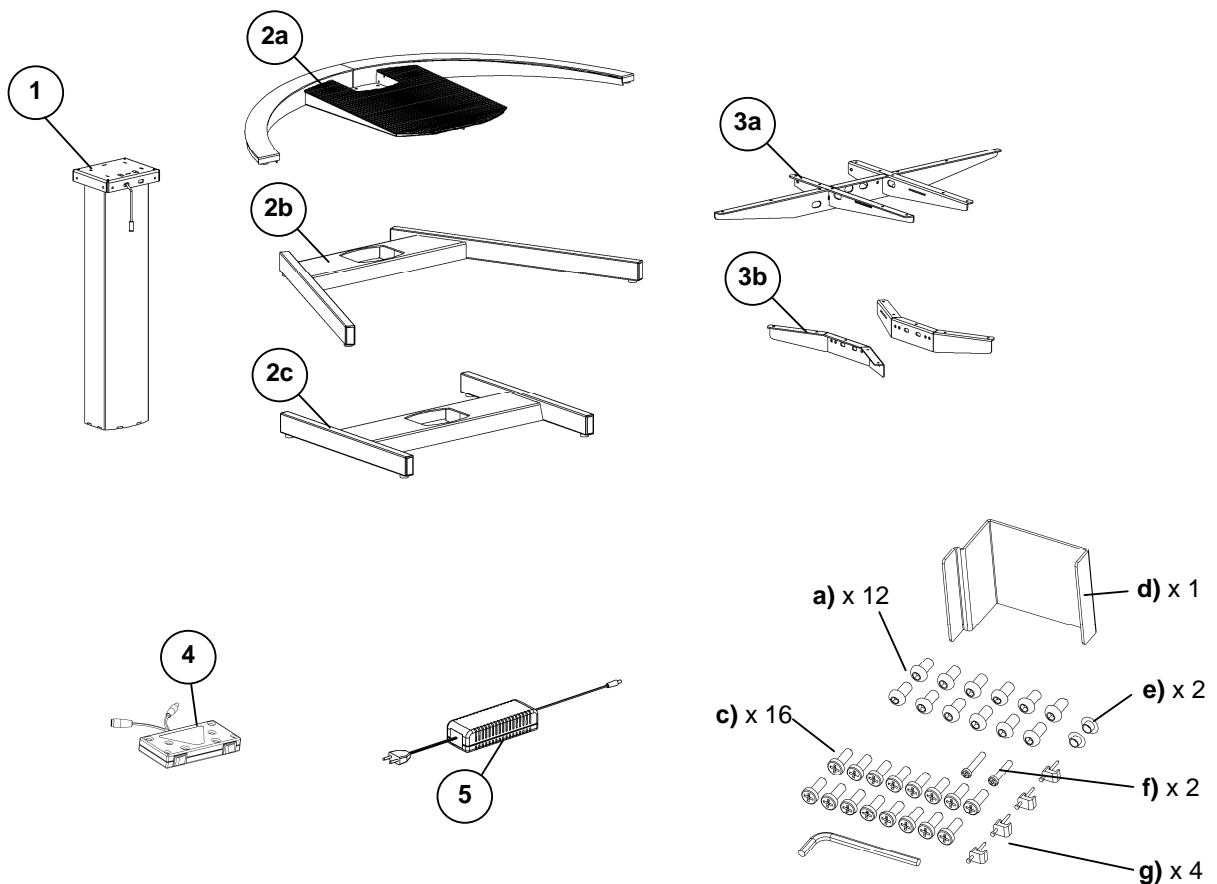

## 8. ASSEMBLY DIRECTIONS

1

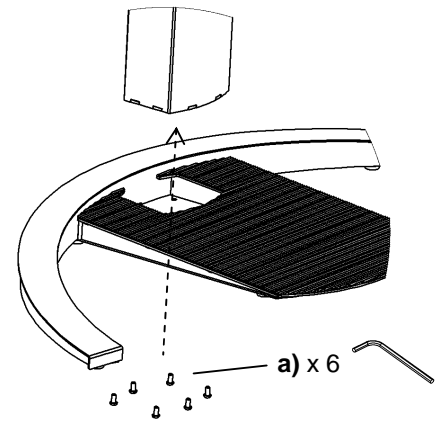
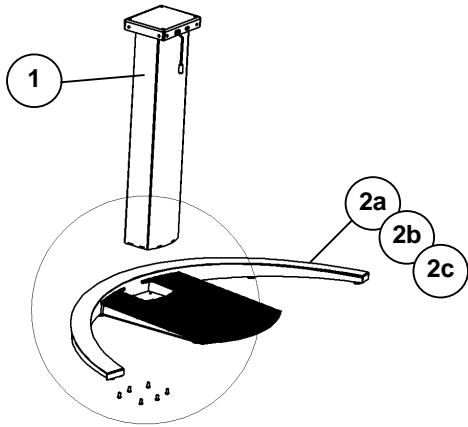

2

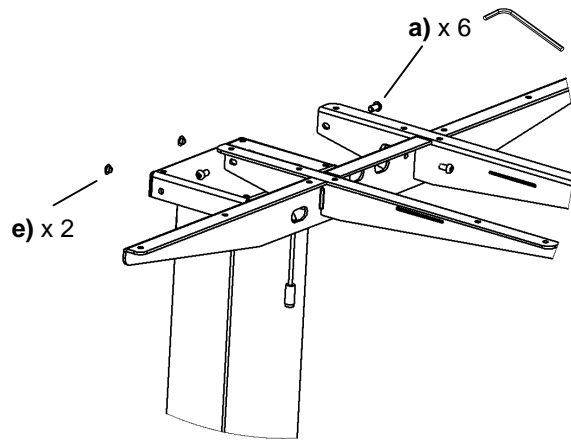
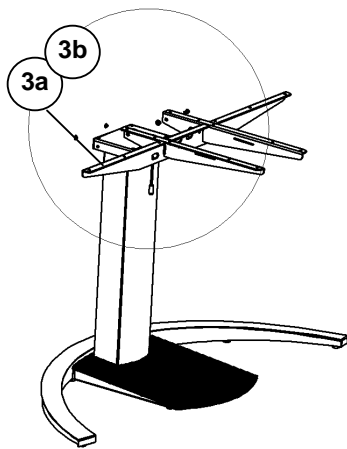

3

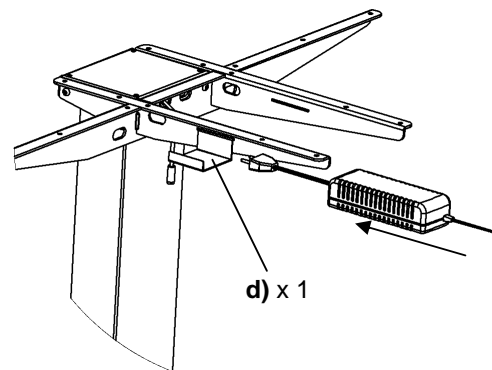
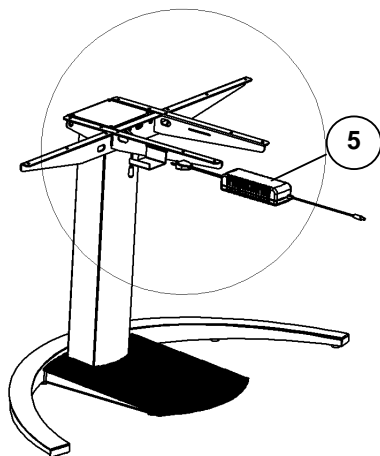

continued....

Assembly directions continued.....

4

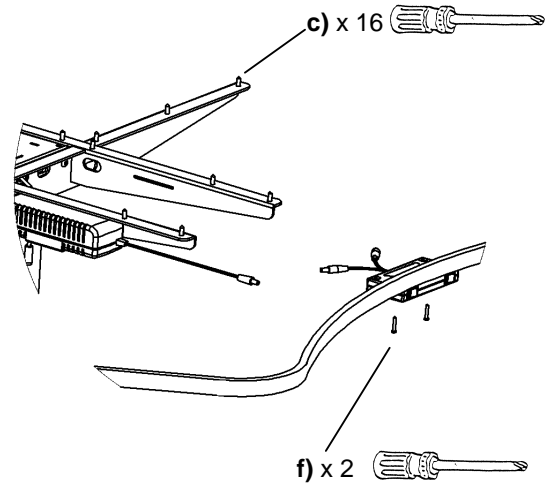
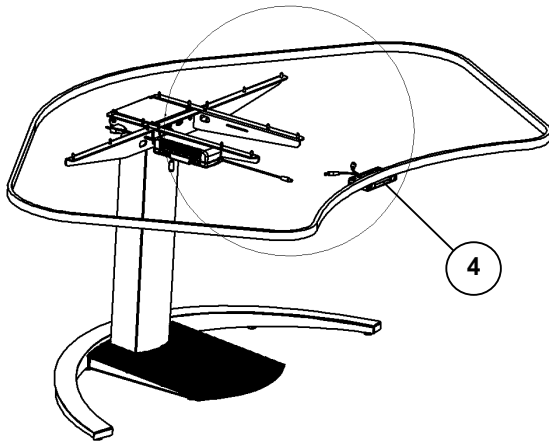

5

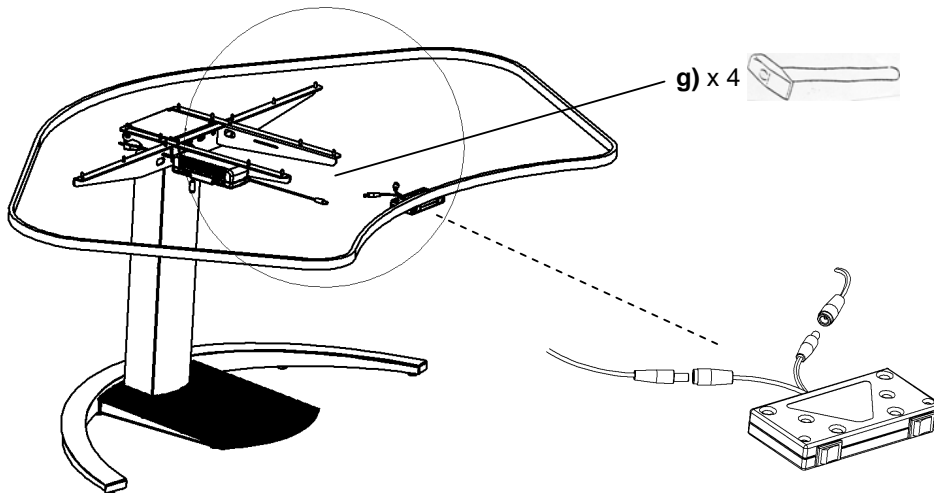

**UP/DOWN operation:**  
BOTH buttons must be  
pressed  
SIMULTANEOUSLY  
either right or left.

The table is now assembled. Follow the directions for use in  
CHAPTER 2.

## 9. DECLARATION OF CONFORMITY

We hereby declare, under our sole responsibility that the following products:

- ConSet sit and stand tables product type 501-19

which are covered by this statement, are in conformity with the following standards and other normative documents::

- Counsel Directive 98/37/EF
- Counsel Directive 89/336/EØF with later changes
- Counsel Directive 73/23/EØF with later changes

With reference to the Machinery Directive (98/37/EF) please be aware:

- the sit and stand table is considered a machine and
- the sit and stand table may not be used until it has been assembled and installed according to the instructions.

**Product data sheet:  
Electric height adjustable desk frame 501-19**

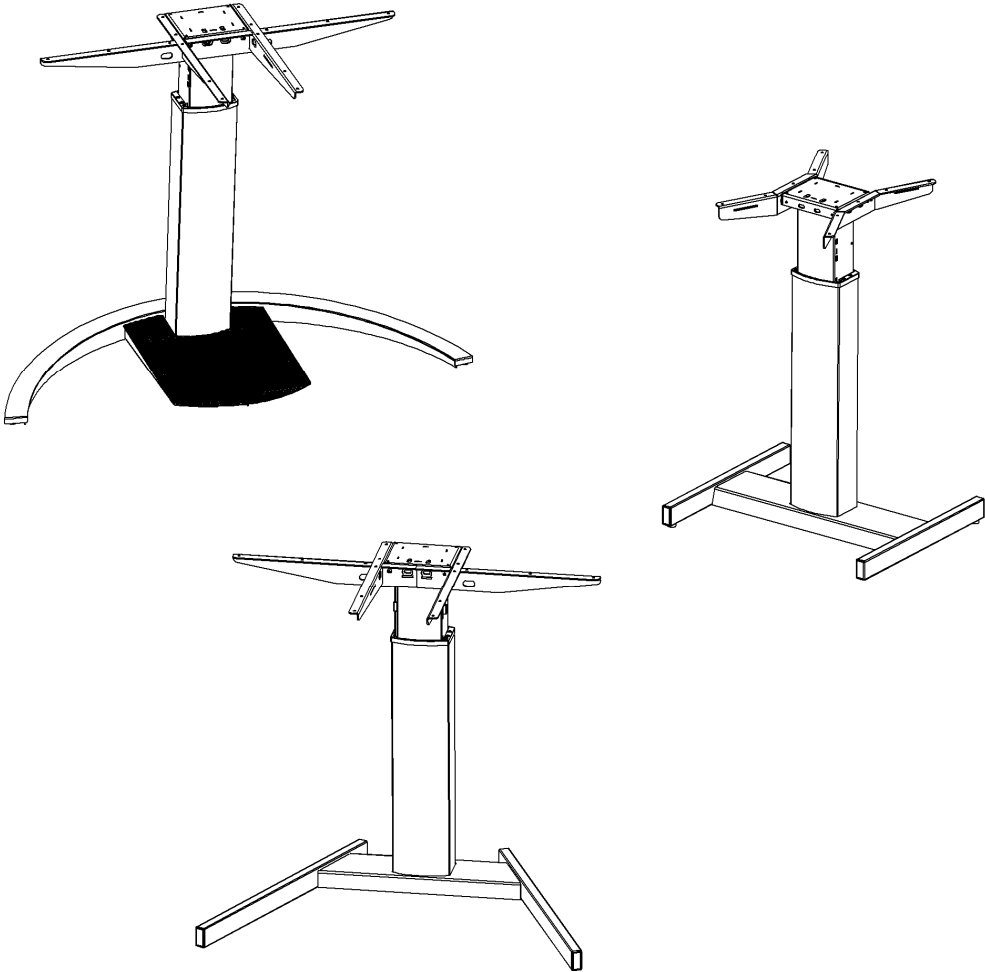



## Table of contents

Packing details, XX120 leg	page 3
Main measures and specifications, XX120 leg	page 4
Packing details, XX095 leg	page 5
Main measures and specifications, XX095 leg	page 6
Packing details, XX060 leg	page 7
Main measures and specifications, XX060 leg	page 8
Tabletop drillings	page 9
Assembly and use	page 12
Safety and tests	page 13
Specification, components	page 14

## Packing details, XX120 leg

### Box Packing

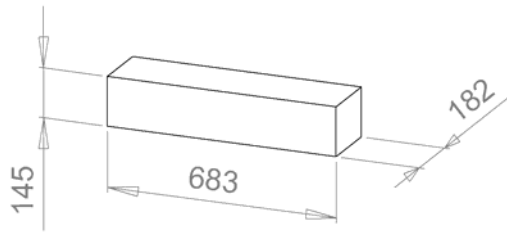

Weight 14 kg

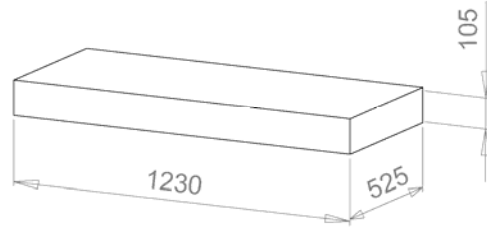

Weight 12 kg

---

### Content of packing

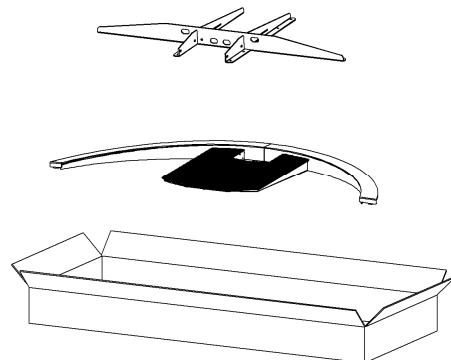
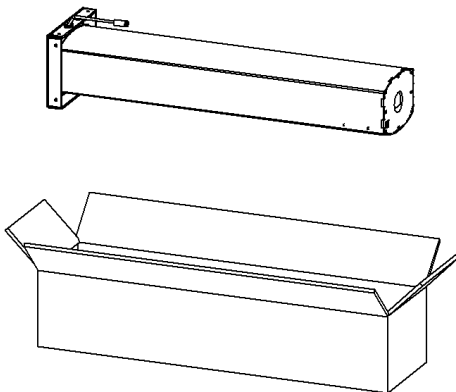

## Main measures and specifications, XX120 leg

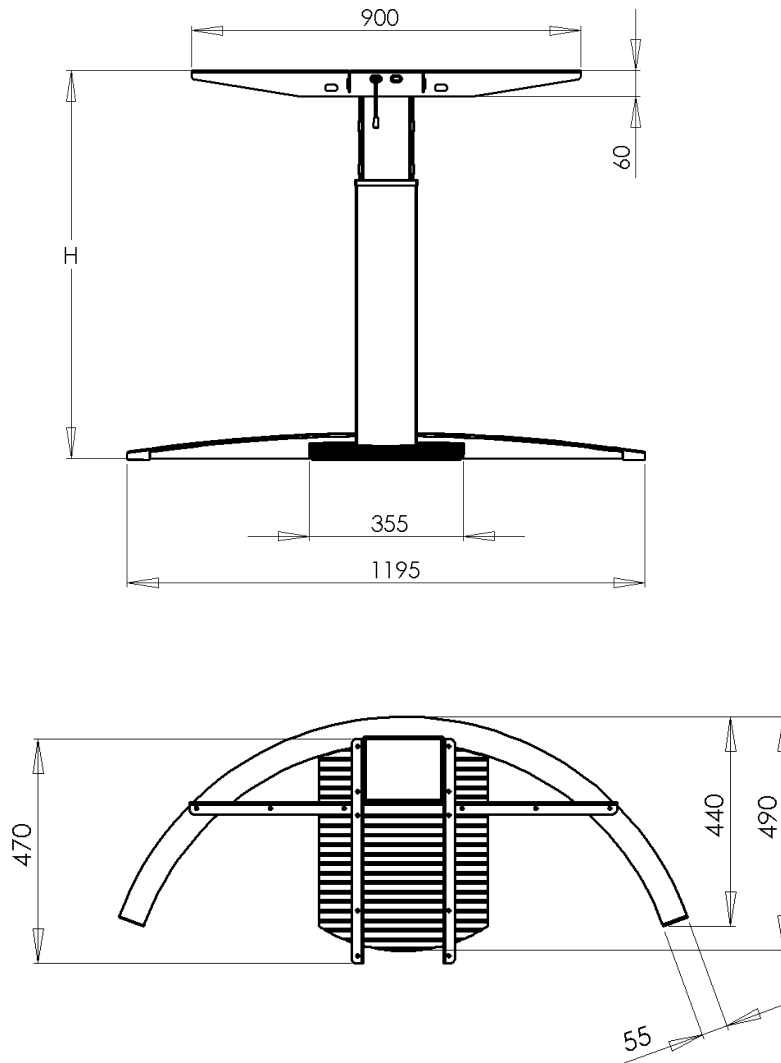

H (height), frame only	66 - 118cm
Lifting capacity, frame	100 kg
Speed	28 mm/sec

If further documentation needed, please find dwg documentation on the website.

## Packing details, XX095 leg

### Box Packing

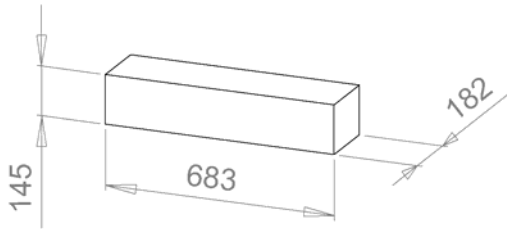

Weight 14 kg

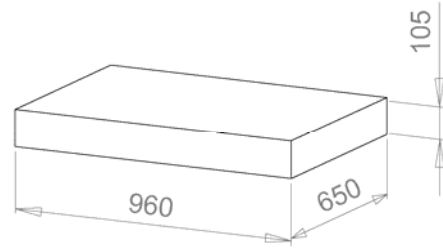

Weight 12 kg

---

### Content of packing

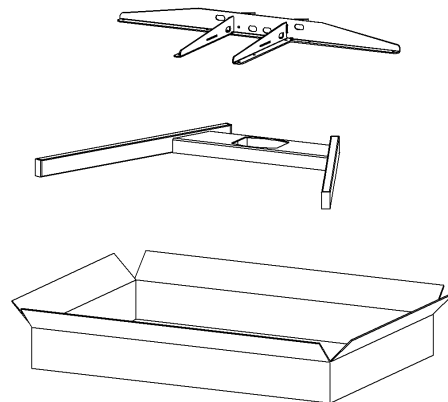
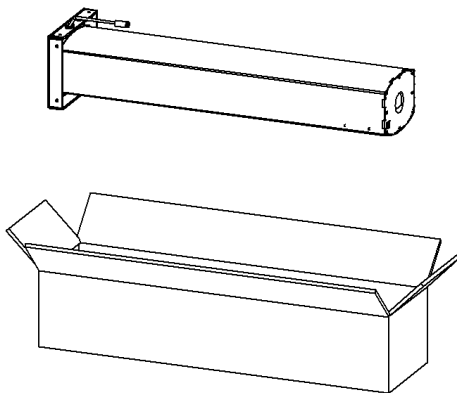

## Main measures and specifications, XX095 leg

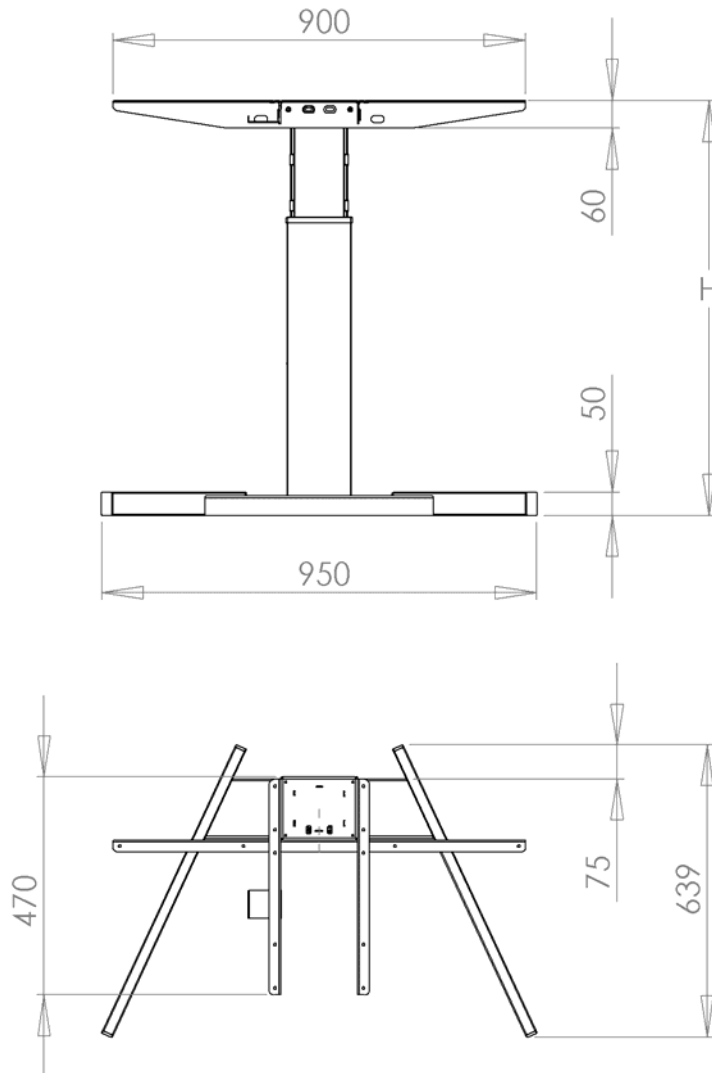

H (height), frame only	66 - 118cm
Lifting capacity, frame	100 kg
Speed	28 mm/sec

If further documentation needed, please find dwg documentation on the website.

## Packing details, XX60 leg

### Box Packing

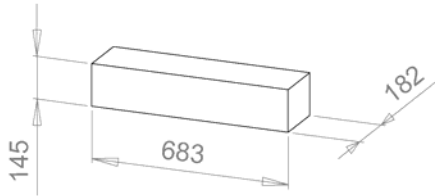

Weight 14 kg

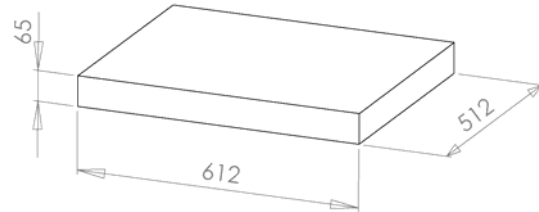

Weight 12 kg

---

### Content of packing

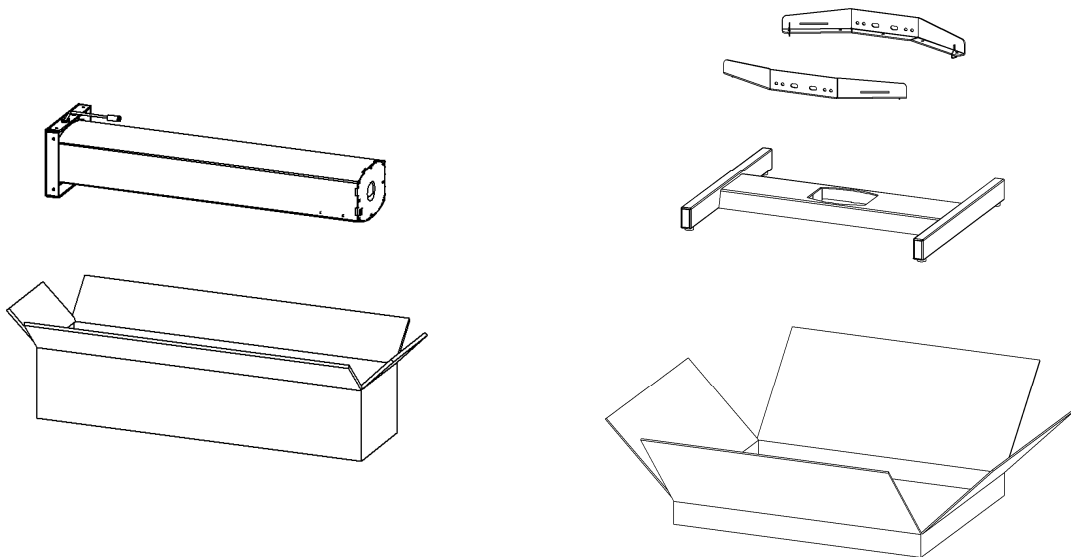

## Main measures and specifications, XX060 leg

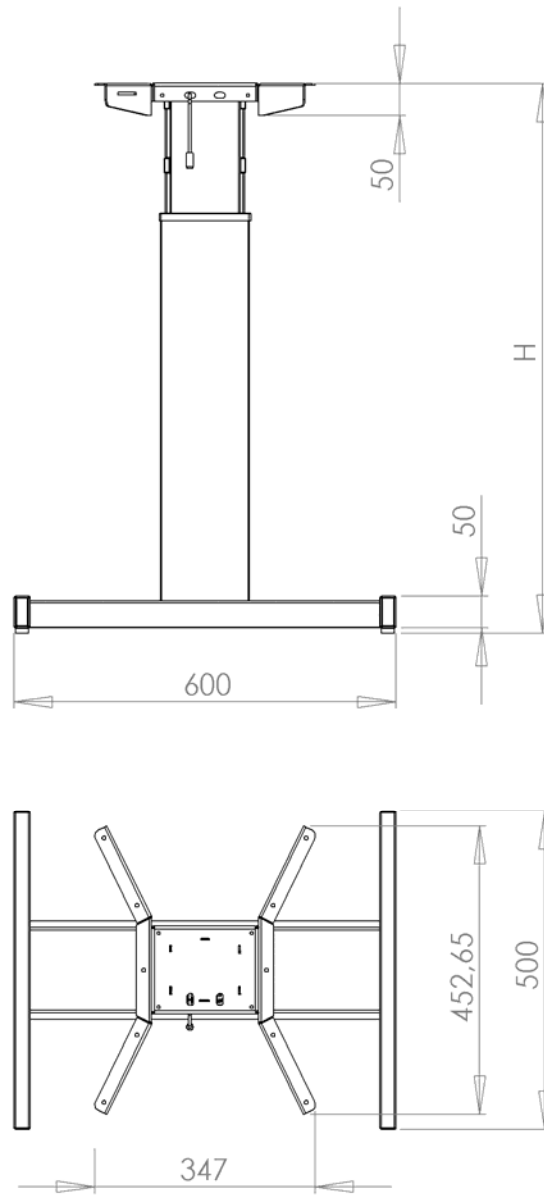

H (height), frame only	66 - 118cm
Lifting capacity, frame	100 kg
Speed	28 mm/sec

# Tabletop drillings

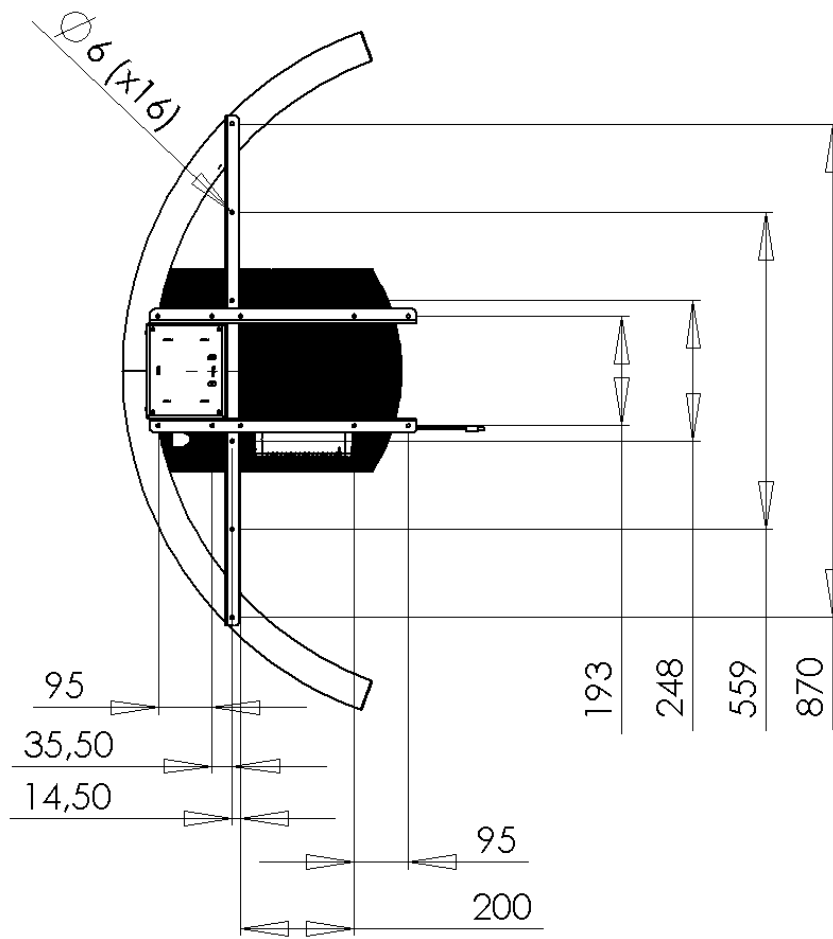



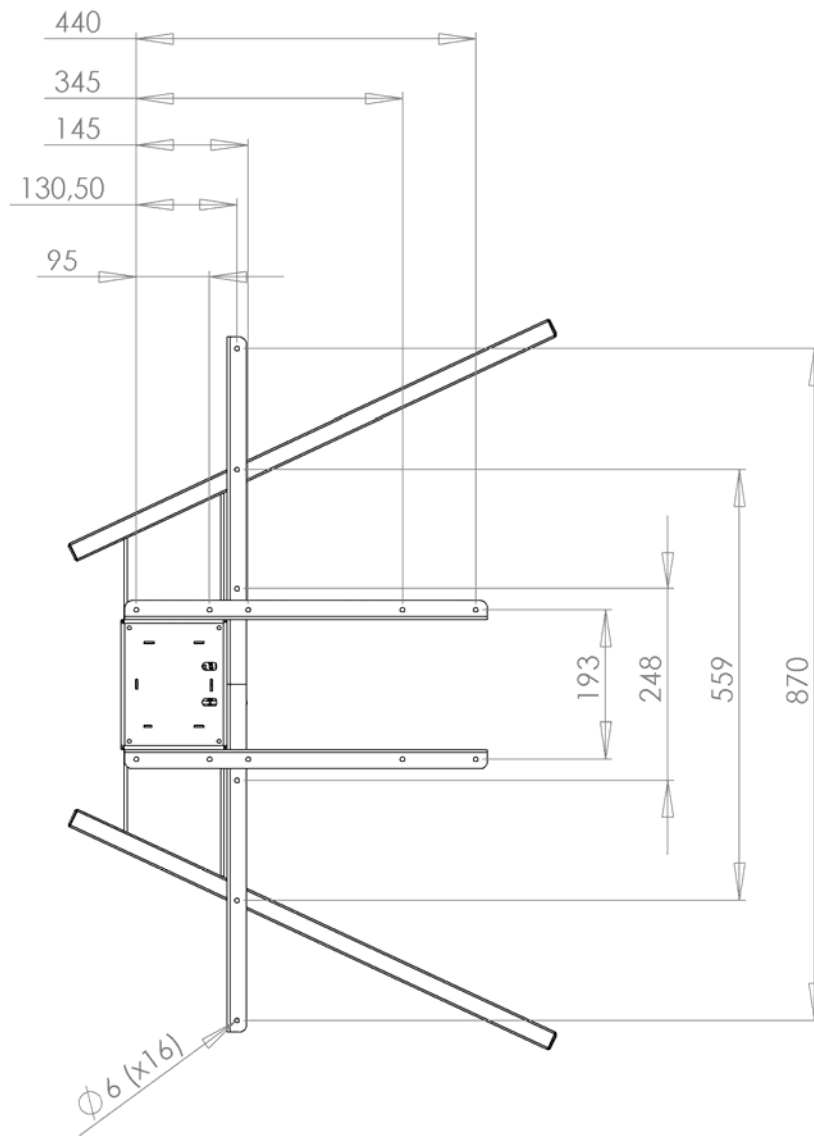

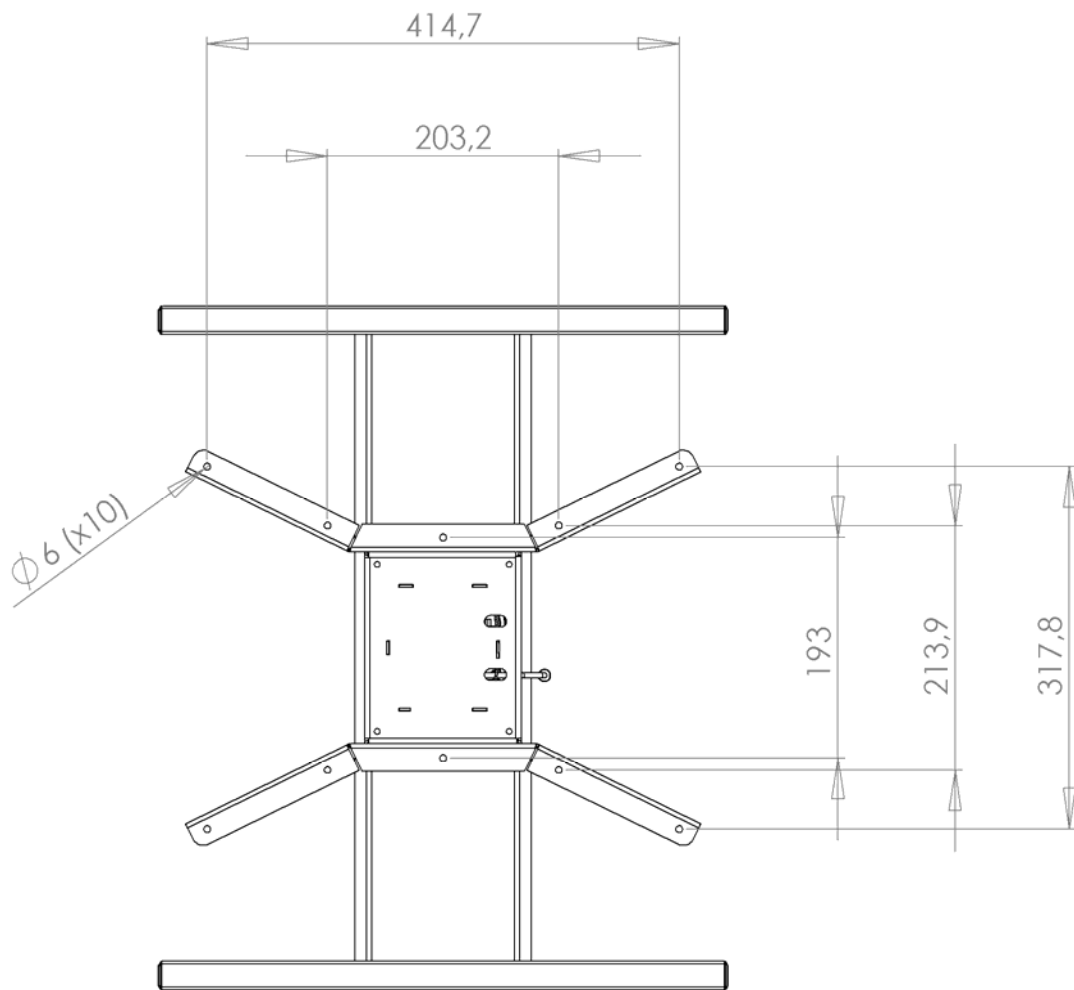

## Assembly and use

Along with all products a “Direction for assembly and use” is delivered. In this you will find a detailed description of the way of assembly.



After the frame has been mounted the chosen tabletop is mounted and the operation unit will be possible to fix at the bottom side of the tabletop. This operation unit has two rocker switches.

With rocker switch A and B it is possible to move the tabletop up and down and can be stopped at all levels. For safety reasons it is necessary to push both buttons at the same time for moving the table up and down.

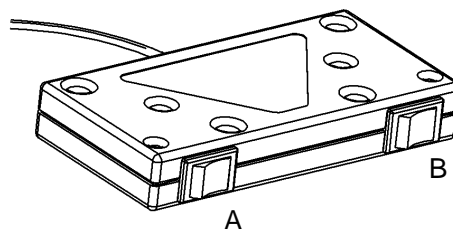

## Safety and tests

All products have been tested up against the following norms:

ISO/DIS 8019

DS/ISO 7172

The norms mention above is possible to find at the website in the section "Norms and approvals".

## DECLARATION OF CONFORMITY

We hereby declare, under our sole responsibility that the following products:

- ConSet sit and stand tables product type 501-19

which are covered by this statement, are in conformity with the following standards and other normative documents::

- Counsel Directive 98/37/EF
- Counsel Directive 89/336/EØF with later changes
- Counsel Directive 73/23/EØF with later changes

With reference to the Machinery Directive (98/37/EF) please be aware:

- the sit and stand table is considered a machine and
- the sit and stand table may not be used until it has been assembled and installed according to the instructions."

## Component specifications

Metal sheet parts: St 37-2

Gear parts: St 70-2

Gear motor: Bosch no. 0 390 257 685

Power supply: 100 W AC Power Transformer  
Consumption: 100 Watts; Standby: Max 0,9 Watts

Plastic components: PA6, POM

Surface treatment Visible metal parts powder coated in "alu" colour, RAL9006  
and black, RAL 9004  
Non visible metal parts are surface treated (e.g. plated)

## How to attach your desktop to your base

### *Rectangular Tops*

1. Assemble desk base per manufacturer's instructions.
2. Using a carpenter's square, configure location where you will attach the desktop per Figure 1:

*Fig. 1*

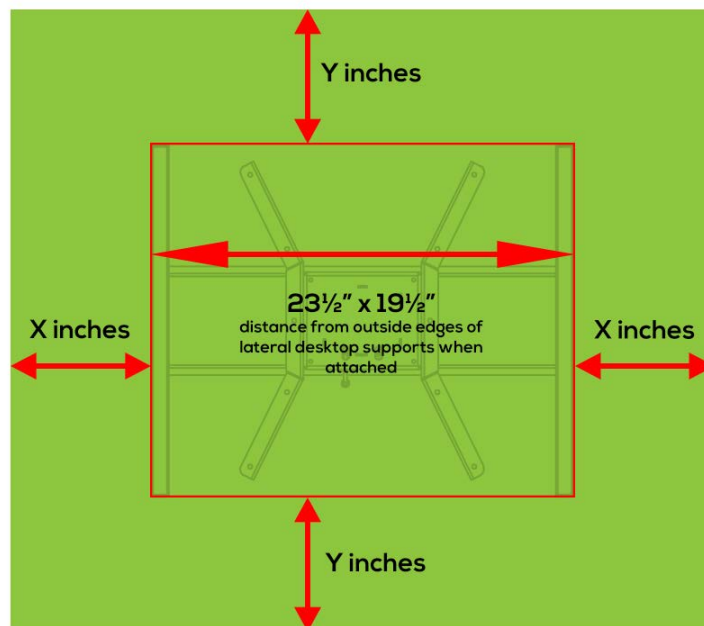

Use the carpenter's square to keep the rectangular profile of the base (represented by red outline) parallel to the edges of the desktop and centered therein. To calculate the "X" distance, subtract 23½" from the overall width of your desktop and divide by 2. To calculate the "Y" distance, subtract 19½" from the overall depth of your desktop and divide by 2. Slight production variations may occur in the base mounting, so slight manual adjustments may be required to perfectly center the desktop.



3. ***Before you insert screws in desktop, do a quick check and make sure your screws are the proper length (make sure they don't pierce the desktop surface!).***
4. Set desktop on base and attach it directly with screws per Figure 2.  
*Leave them loose to start as you will likely have to make small adjustments for a snug fit with the base. Do not overtighten.*

# User Manual

programmable handset

This programmable handset is an optional accessory. Program three height settings each for up to three individual users. At anytime, you can use the **UP/DOWN** buttons to adjust the height of the table without affecting the programmed heights.

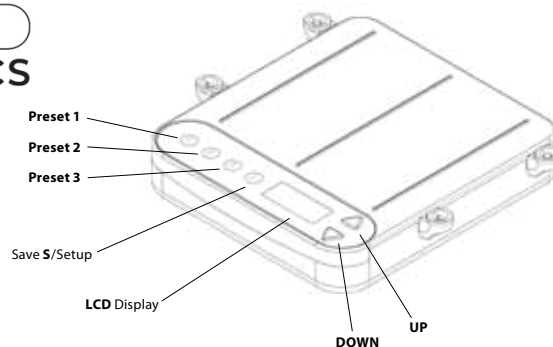

## Step 1 – program the series it is being used for (Figure 1)

- Press **S** for 10 seconds until the *model setup menu* is activated. (Be aware that the *user select menu* will display after 2 seconds. Continue to press the button).
- Use setup setting **P9**
- Press the **S** button again to save.
- Now raise the desk to the full height so that the maximum height is indicated by the display

Figure 1

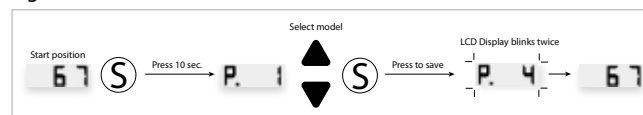

## Step 2 – program or change the preset heights for each user

For this example we will assume there are three users: Jess as *user 1*, Max as *user 2* and Sam as *user 3* (Figure 2). You can set the heights in centimeters or inches.

- Press **S** for 2 seconds until the user menu is activated.
- Jess will select *user 1* with the **UP/DOWN** buttons.
- Press the **S** button again to save.

### Press the **S + UP** to see cm or **S + DOWN** for inches, for 2 seconds.

Jess has selected to display inches and is the first to set up her favourite three heights of 30.0", 33.0" and for standing she requires 40.5".

- Now she moves the desk height to 30.0" using the **UP/DOWN** buttons.
- Next she must press **S** followed by **Preset 1** and hold both for 2 seconds. The **LCD Display** blinks twice then release the button. **Preset 1** is now stored at 30.0".

Jess now repeats this process to store **Preset 2** at 33.0" and **Preset 3** at 40.5".

Max, *user 2*, and Sam, *user 3*, can now enter their settings and switch to view centimeters instead of inches at any time.

\*Press the **S + UP** to see cm or **S + DOWN** for inches, for 2 seconds.

## Step 3 – use your Preset positions

- First Jess must check *user 1* is selected or select this via **step 2 a)** and **b)**.
- Now Jess wants to stand up to work so she must press and hold **Preset 3**. The table will move and when 40.5" is reached it will stop automatically and the display will blink twice. Jess can release the button. For safety the table will stop if you release the button to early.

Figure 2

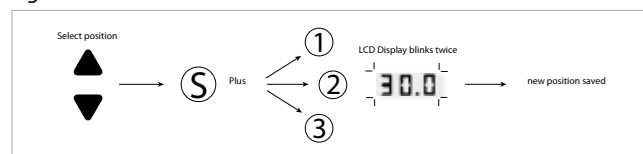





**Finishes Available for Standard-edge Desktops**

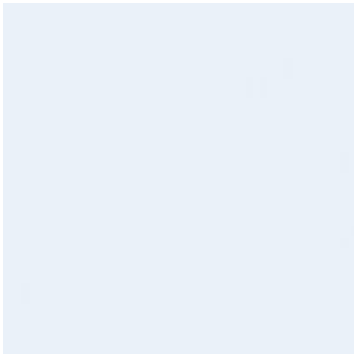

White White 777



Sunset Grey

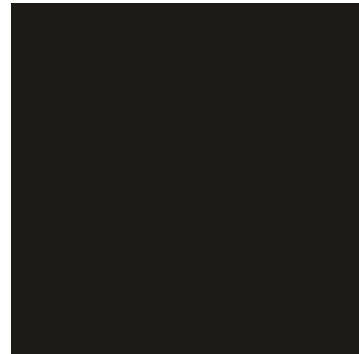

Black



Acacia G63



Dark Mountain Oak G57

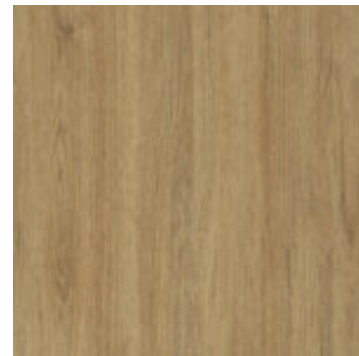

Ginger Root H72



Dalia K24



## Warranty

### **1.B1CA\*D†                      Height-adjustable Desk with Single-leg Basic Base**

The manufacturer warrants to the original purchaser that the products it manufactures are free from defects in design, material and workmanship. With prompt written notice, the manufacturer will repair or replace, free of charge, any product, part or component which fails under normal use as a result of such defect.

The following exceptions to the warranty do apply:

- Electric components and motors are limited to 5 years, under normal operational conditions, subject to the inspection and determination of the manufacturer.
- Steel parts are limited to 5 years.

This warranty does not apply to:

- Damage in shipment caused by a carrier
- Defects caused by improper installation
- COM or third party materials applied to the products
- Customer modifications to the product
- Products subject to improper use and conditions.