

ERGOADVANTAGE™

BY APPLIED ERGONOMICS

64.SA01BT-PLT

ErgoAdvantage Modula Single Monitor Arm

US Patent: 6,695,270 B1
6,758,454 B2
7,316,377 B2

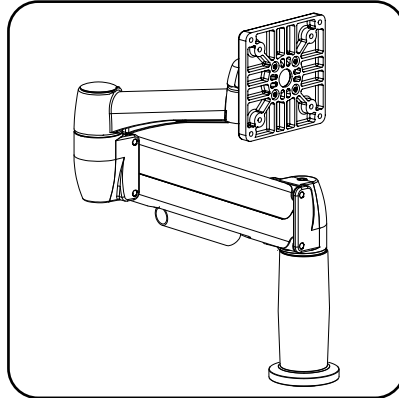

Required Tools:

- 17 mm Socket
- 5mm Allen Key
- #2 Phillips Screwdriver

Contents:

#	QTY	Part Name
1	01	T-Nut
2	01	Bolt Through Base Plate
3	01	Double Hub
4	01	M10 Washer
5	01	M10 Bolt
6	01	Plastic Washer
7	08	Monitor Screws
8	01	Standard SpaceArm

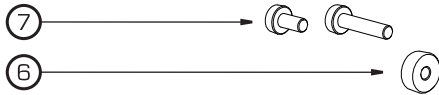

Monitor Mounting

Hardware package includes both short and long screws and plastic washers. The long screws & plastic washers should be used for recessed monitor mounts.

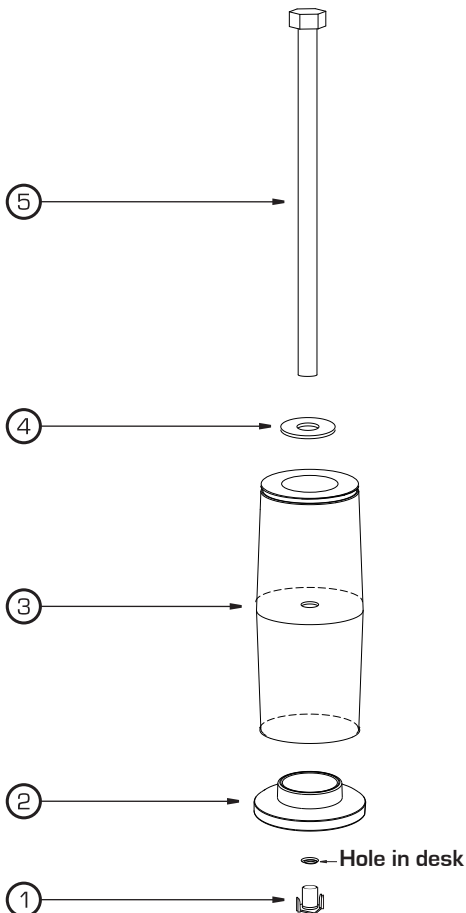

Adjusting Counter Balance *Required Tool: 5mm Allen Wrench

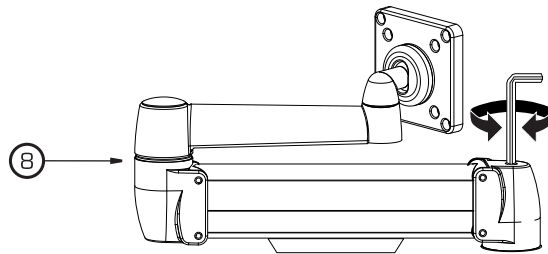

Position Arm so it is parallel to desk surface.
Turn bolt clock wise for lighter monitors.

Cable Routing

