

BASEFRAME MOUNTING TEMPLATE

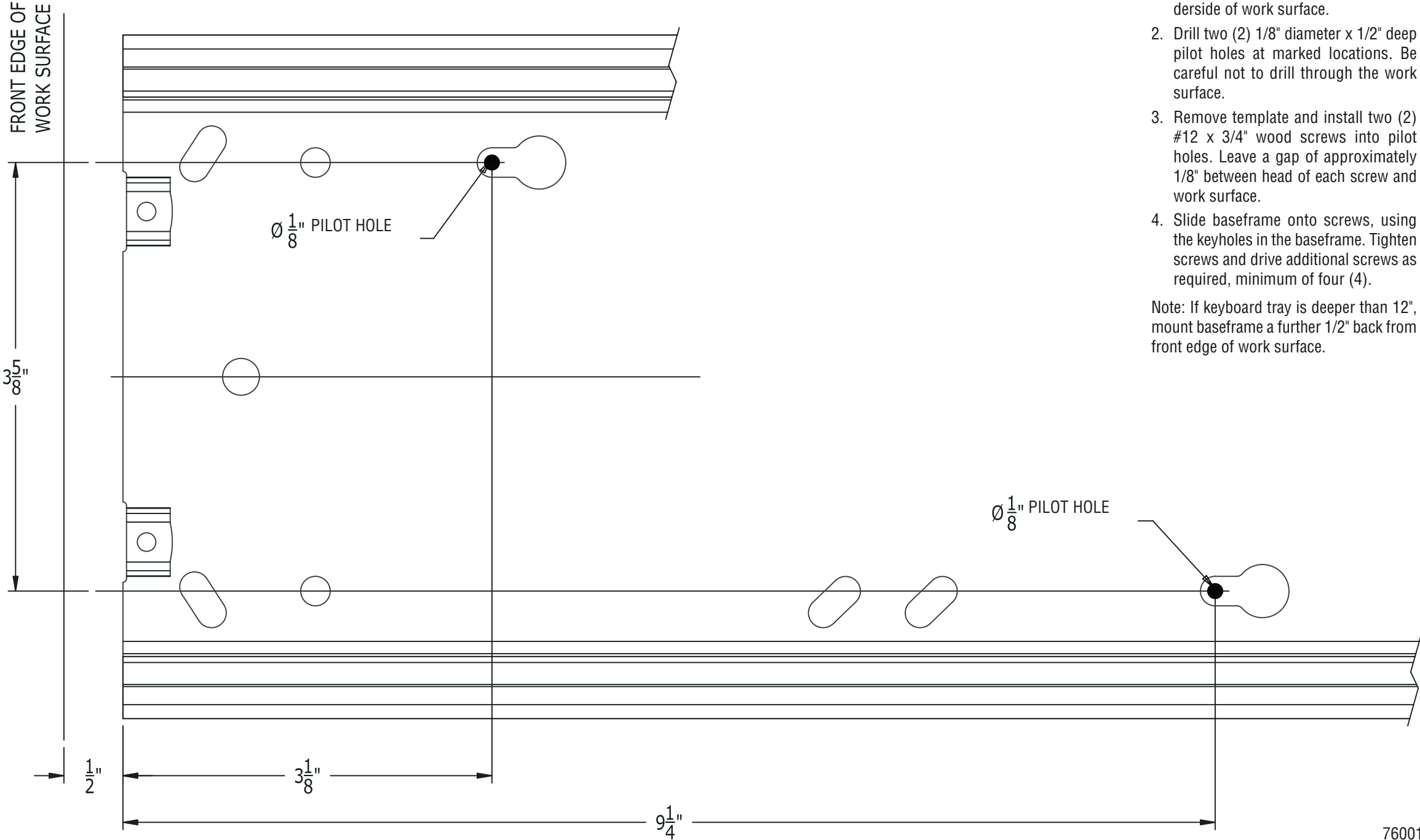

1. Tape this mounting template to the underside of work surface.
2. Drill two (2) $\frac{1}{8}$ " diameter x $\frac{1}{2}$ " deep pilot holes at marked locations. Be careful not to drill through the work surface.
3. Remove template and install two (2) #12 x $\frac{3}{4}$ " wood screws into pilot holes. Leave a gap of approximately $\frac{1}{8}$ " between head of each screw and work surface.
4. Slide baseframe onto screws, using the keyholes in the baseframe. Tighten screws and drive additional screws as required, minimum of four (4).

Note: If keyboard tray is deeper than 12", mount baseframe a further $\frac{1}{2}$ " back from front edge of work surface.