

ErgoAdvantage Modula Multi-flex Mount - SA01

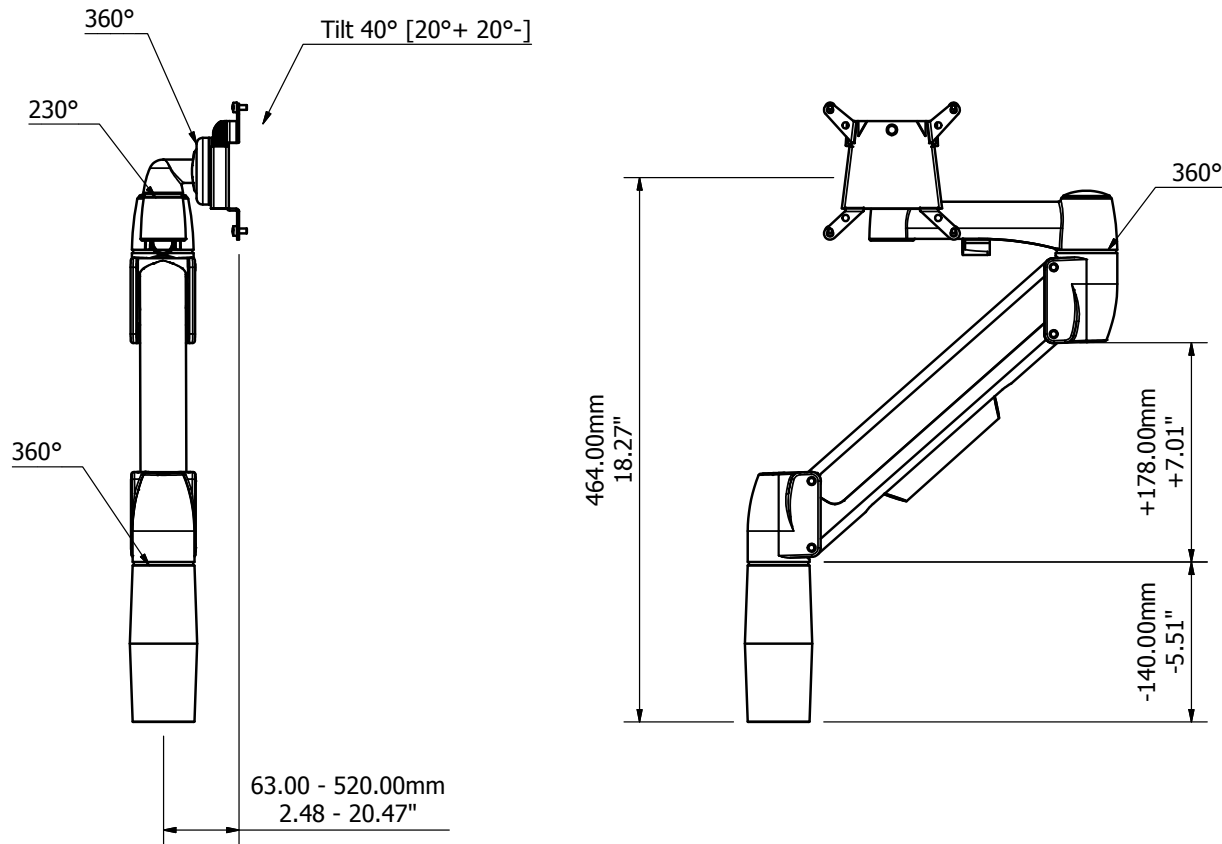

Adjustment	5mm Allen Key
Monitor Weight	Lightweight - (0.9kg - 4.53kg) Standard - (2.26kg - 7.25kg) Heavy Duty - (6.80kg - 13.6kg).
Mounting	75mm and 100mm VESA Mounting Centres, 'Quick Change' or 'Direct Mount'
Construction	Aluminium die casting, steel and nylon
Finish & Colour	Powder coated, Platinum, Black, White or Soft White.
Fixings	Included for mounting and monitor
Packaging	Product dependent

These drawings are based on the Quick Change mounting option.

C-Clamp

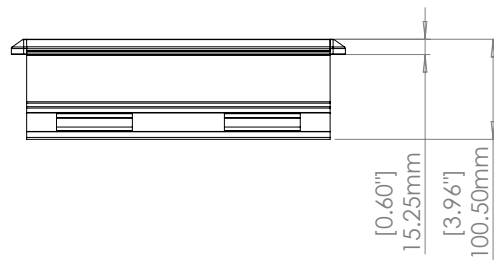
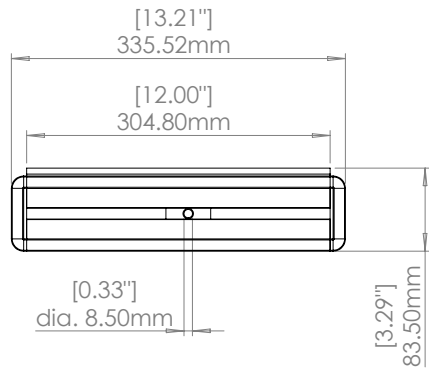
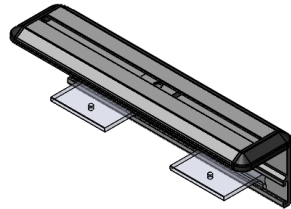

Bolt-Through

