

Required Tools:

**17 mm socket and extension
5mm Allen wrench**

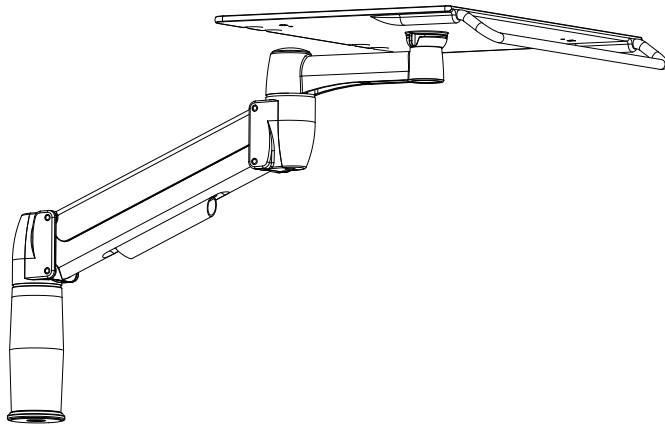

US Patent: 6,695,270 B1 6,758,454 B2 7,316,377 B2

ERGOADVANTAGE™
BY APPLIED ERGONOMICS

SA01LPBT

ErgoAdvantage Modula
Laptop Monitor Arm

Adjusting Counter Balance

*** Required Tool: 5mm Allen Wrench**

**Position Arm
so it is parallel
to desk surface.**

**Turn bolt
clock wise
for Lighter monitors.
Turn bolt counter
clockwise heavier
monitors.**

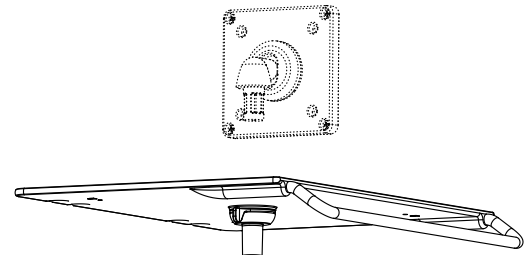
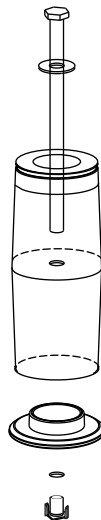
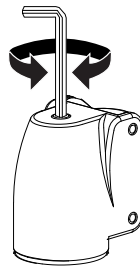

DISCLAIMER OF DAMAGES FOR IMPROPER USE. SpaceCo shall not be responsible for damage to its products, or injuries or damages caused by its products, resulting from improper installation, maintenance, unintended use or attempts to operate such products beyond their mechanical capacity, intentionally or otherwise, or by reason of unauthorized repair.



Please make an appointment to visit us at:
3401 Madison Street
Skokie, IL 60076

Call us
(847) 679-5148
Toll-free: (844) 859-9247
Fax: (847) 933-0018

Email the President directly
jmeltzer@appliedergonomics.com