

QuickStand™•Eco

INSTALLATION INSTRUCTIONS

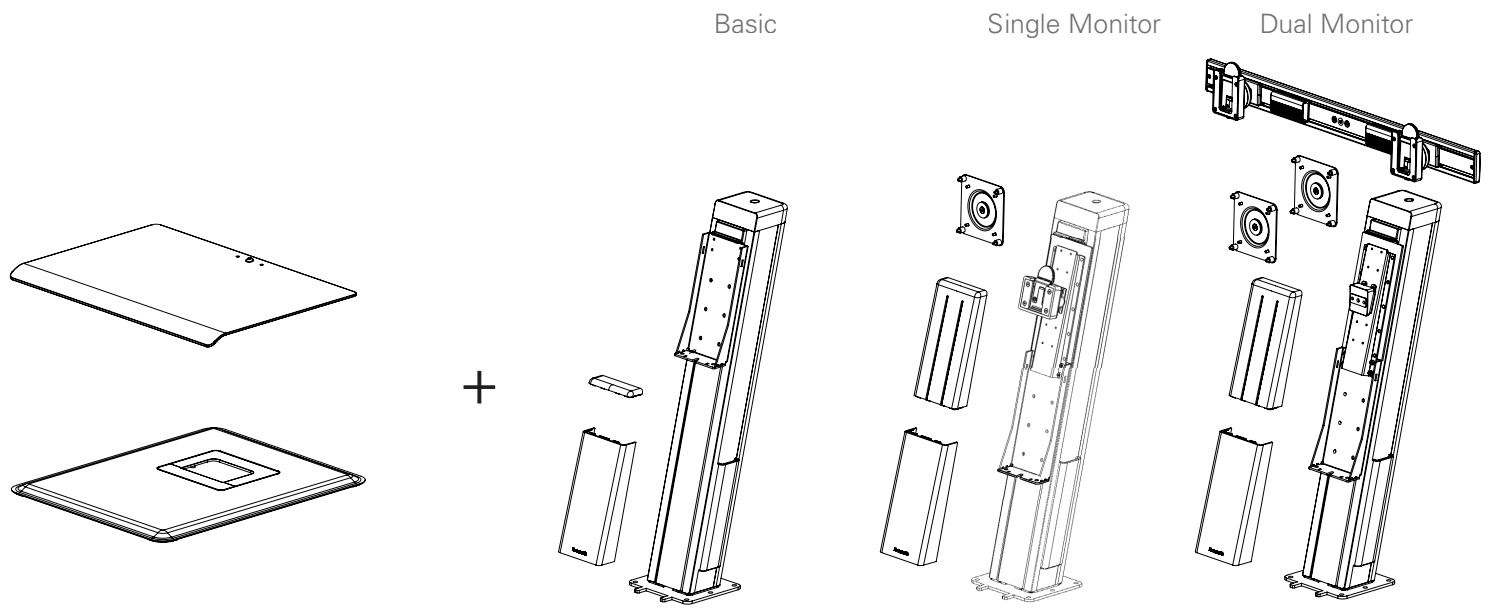

PARTS REQUIRED



(package contents will depend on configuration ordered)

Tools required for installation

2.5 mm Hex Key (included)

6.0 mm Hex Key (included)

Phillips head screw driver

STEP 1

- Place the base on a desk and remove the plastic covers and set them aside.

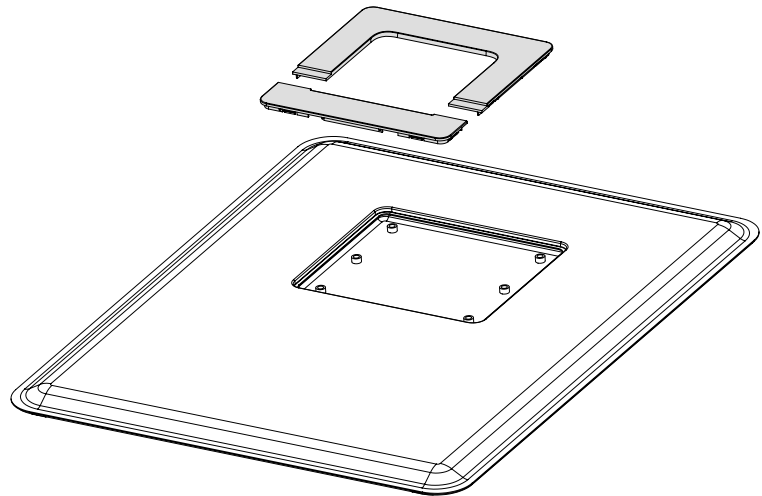

STEP 2

- Slide the main post onto the base by inserting the 2 tabs in the front and secure the main post with 6 screws.
- Snap on the plastic covers removed in step1. Rear cover first then front cover.

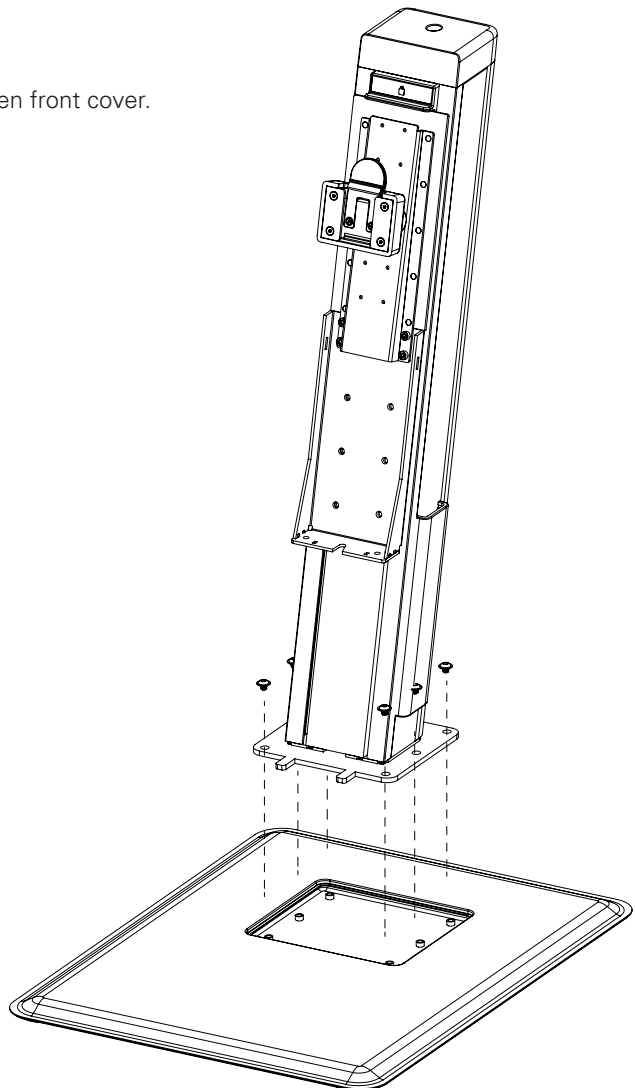
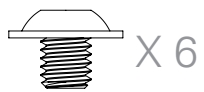

STEP 3

- The support bracket is slotted, slide the preinstalled screw and work surface into the slotted position. This will allow you to support the work surface on the end with one hand and use your other hand to insert and secure the other two screws. Tighten securely with the 6mm ball pointz allen wrench.

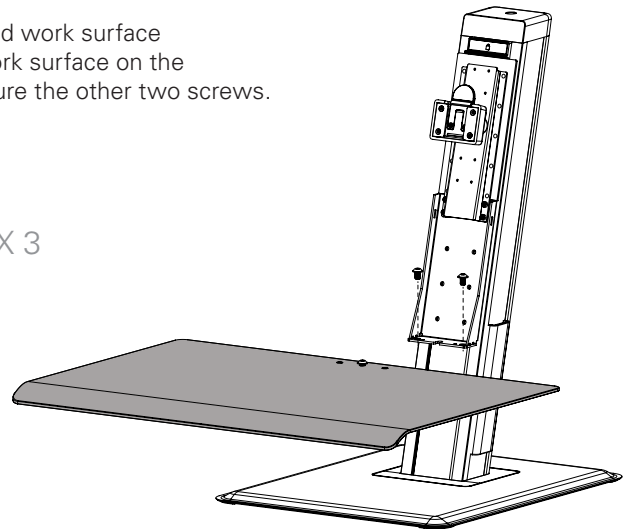
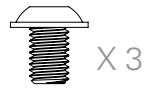

STEP 4

- Attach the Vesa plate onto the monitor(s).

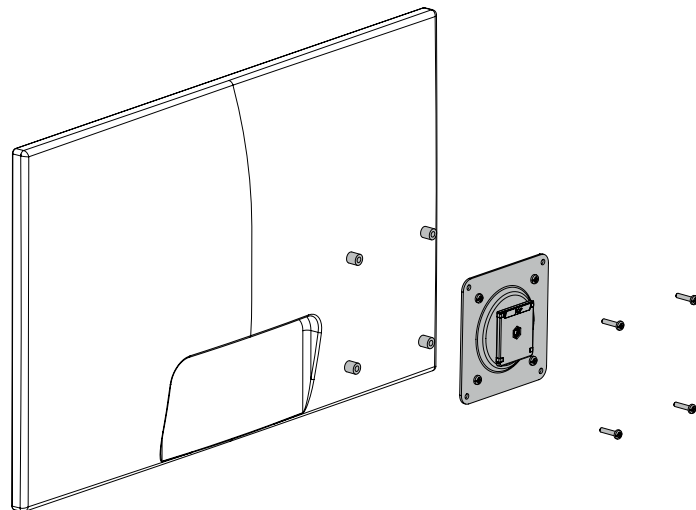

STEP 5

- Reposition the 4 monitor height screws if necessary. Refer to the chart for recommended screw location.

- To adjust height, loosen the 4 screws shown here with the 2.5mm hex key and lift & pull to remove the monitor mount off the unit. Relocate the screws to the desired monitor height then tighten the screws.

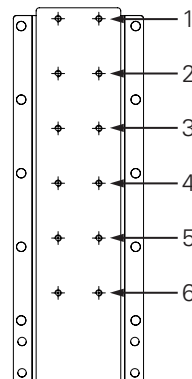
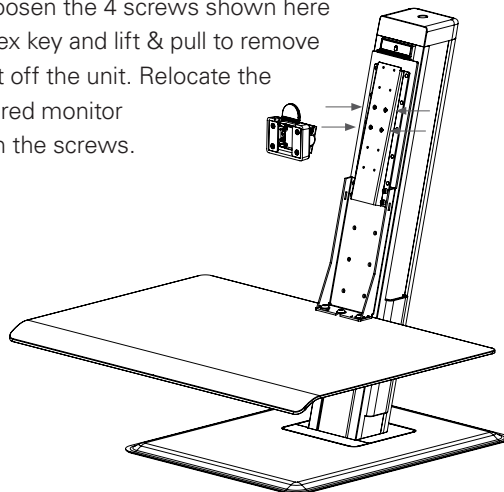

Height (cm/ft)	Use hole numbers
190cm / 6.2'	1&2
180cm / 6'	2&3
175cm / 5.75'	3&4
170cm / 5.5'	4&5
165cm / 5.4'	5&6

STEP 6 (FOR SINGLE MONITOR)

- Attach the monitor to the unit by sliding the Vesa plate tab in from the top.

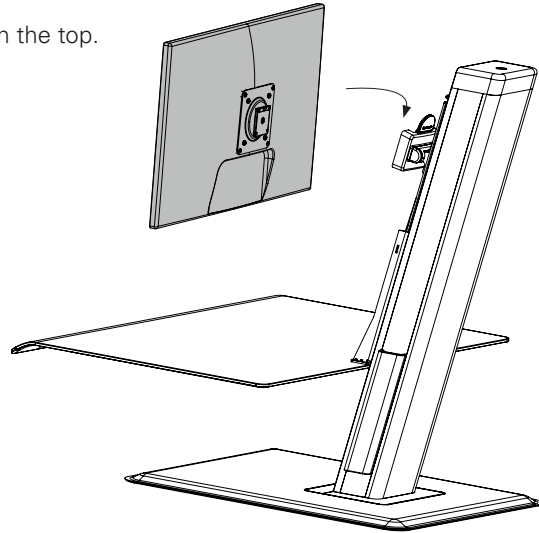

STEP 6A (FOR DUAL MONITOR)

- Attach the crossbar to the unit.
- Attach both monitors to the crossbar.
Refer to the crossbar installation manual.

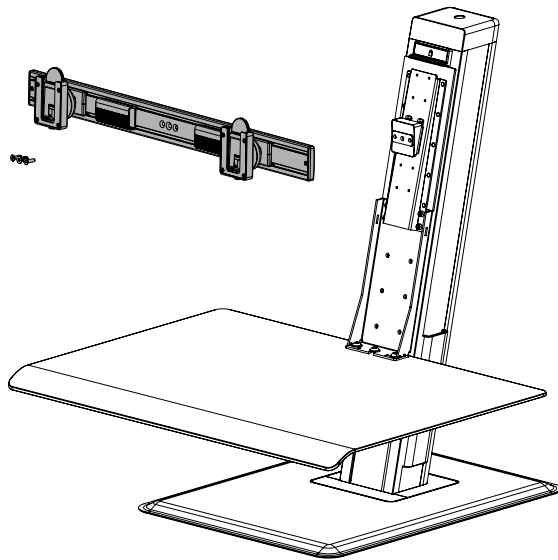

STEP 7

- Push the keyboard platform lower to remove the lock piece.

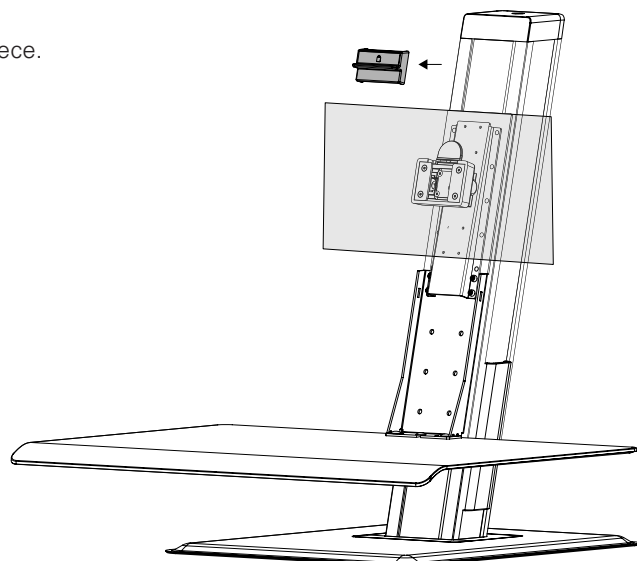

STEP 8

Attach the plastic covers

- Make sure the tabs on the lower plastic cover slides into the slot in the bracket.
- Upper cover slides in from the top behind the monitor mount bracket.

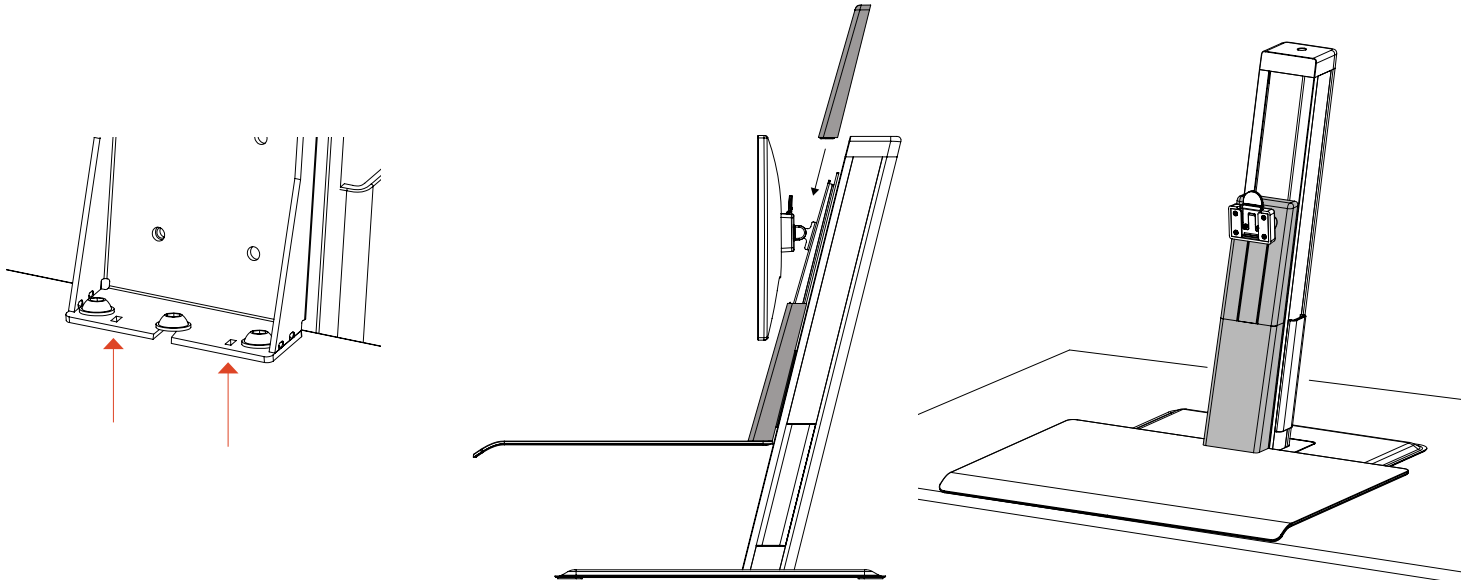

STEP 9

Adjust the counter balance system

- Using the 6mm hex tool, rotate the screw located on the top clockwise until forces pushing the keyboard platform up and down becomes about equal.
- Clockwise to increase upward force and counter clockwise to lower upward force.

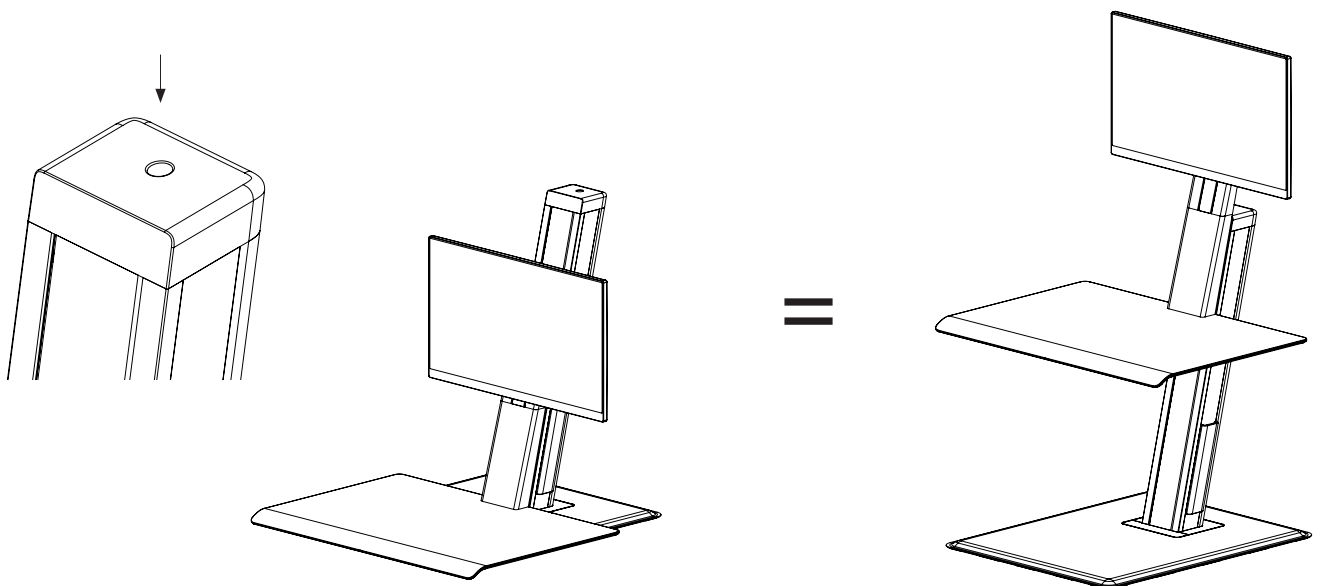

STEP 10

- Keyboard platform at its highest position, remove the cable cover and feed the power and video cables through the clips shown here.

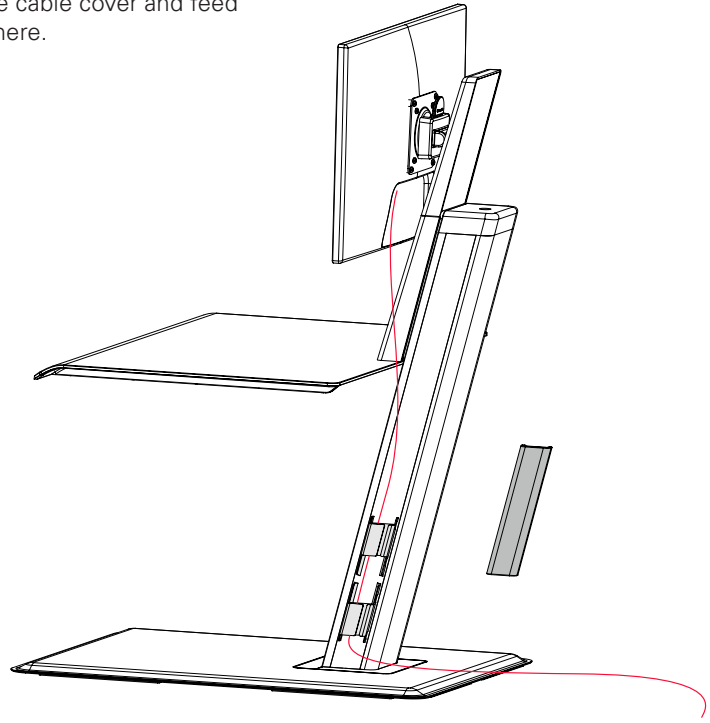

STEP 10A (FOR MODELS WITH CABLE COVERS)

- Bundle the cables with the cable wrap and tie each ends.

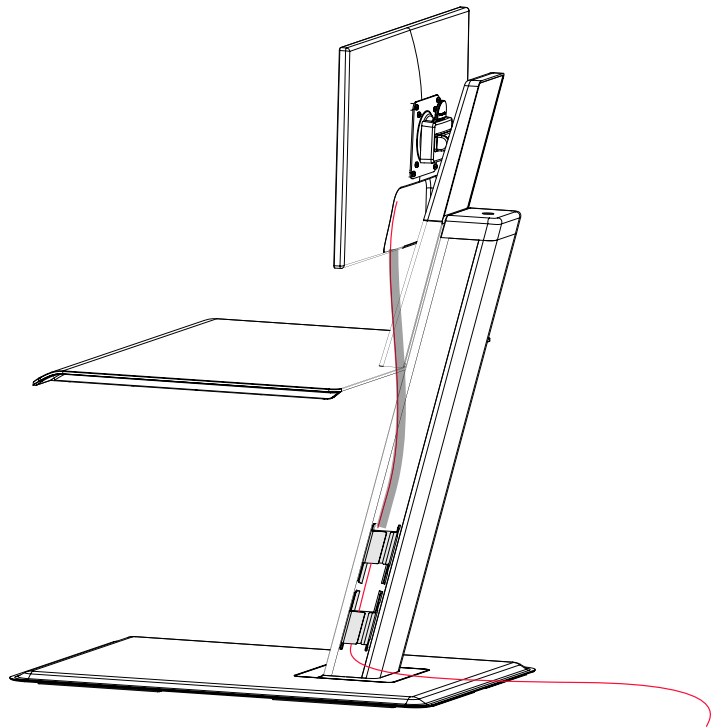

STEP 11

- Install the cable cover back on.
- Repeat these steps on the other side for dual monitor.

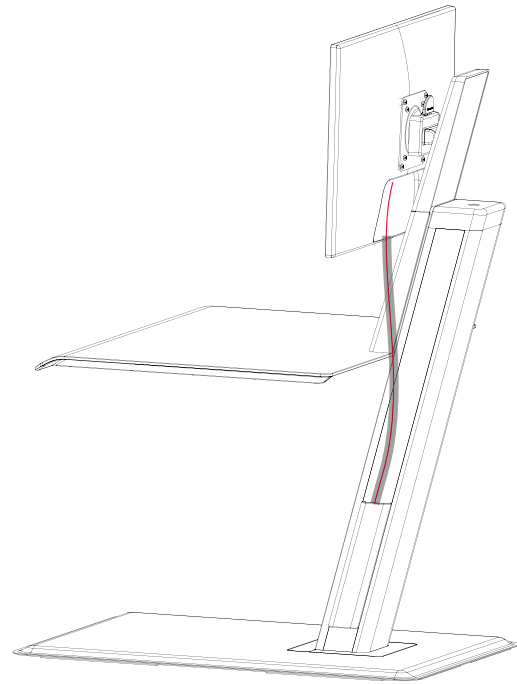

Single Monitor

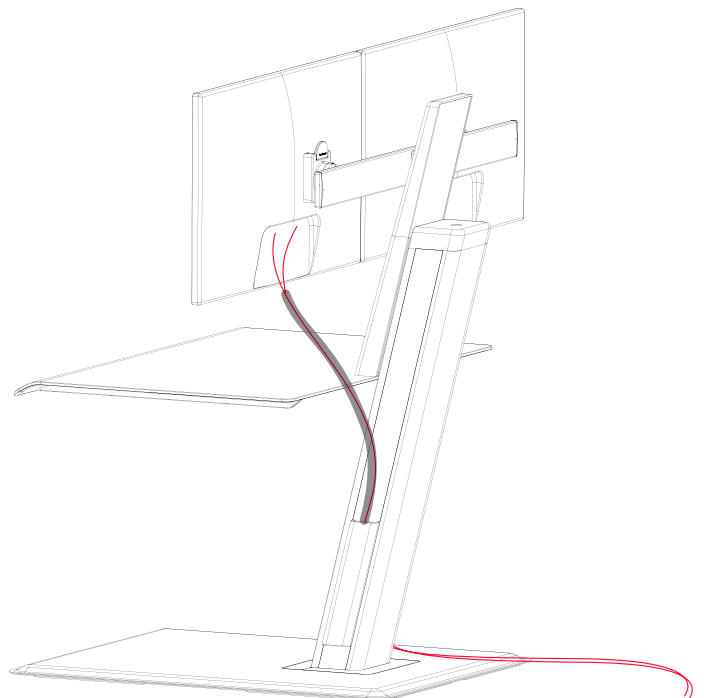

Dual Monitor

CONVERSION FROM LAPTOP TO SINGLE/DUAL MONITOR

STEP 1

- Remove the top cover.

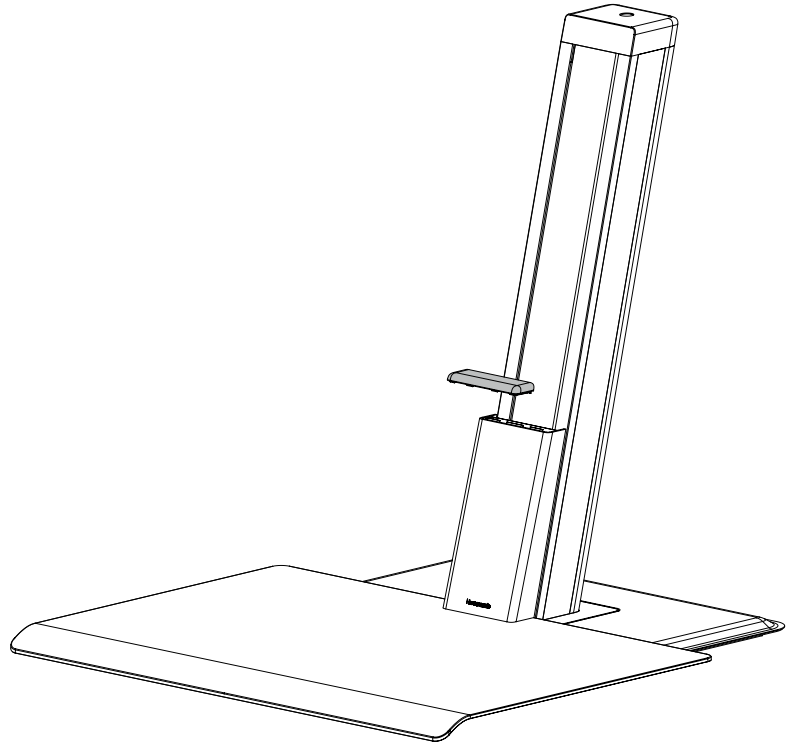

STEP 2

- Remove the front cover by slightly sliding it upwards and pull forward.

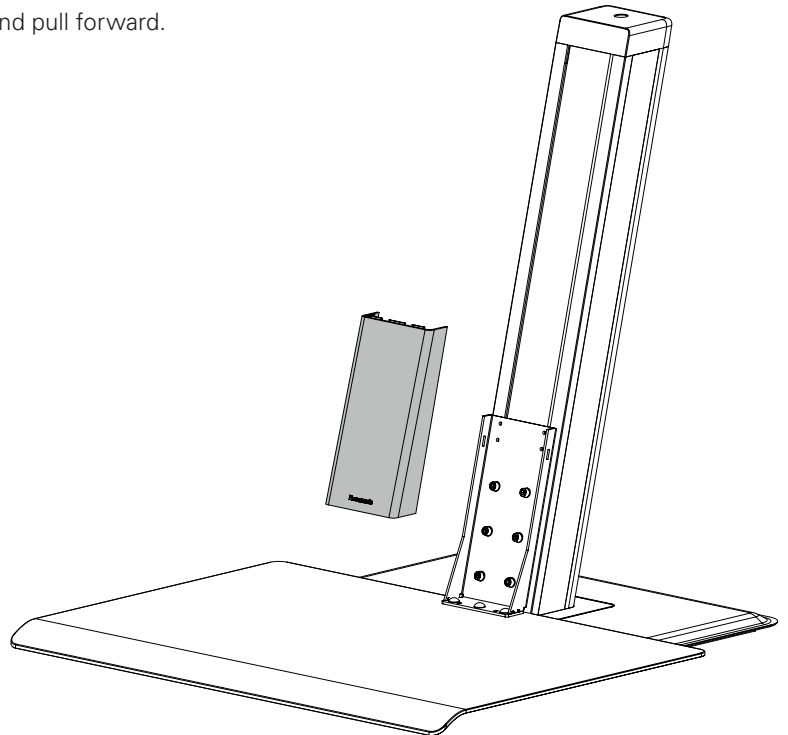

STEP 3

- Attach the monitor mount bracket.

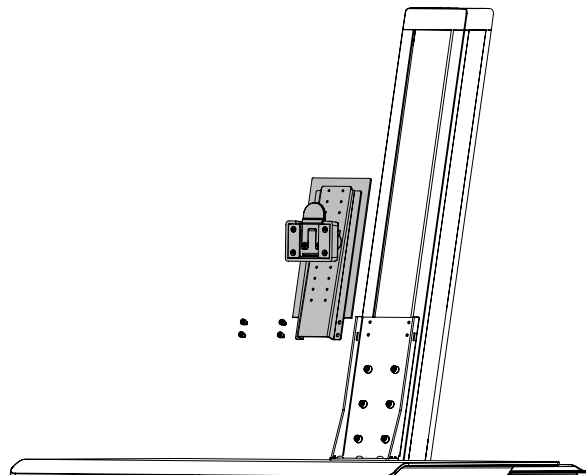

STEP 4

- Attach the front covers.
(Upper front cover slides in from the top behind the monitor mounting bracket).

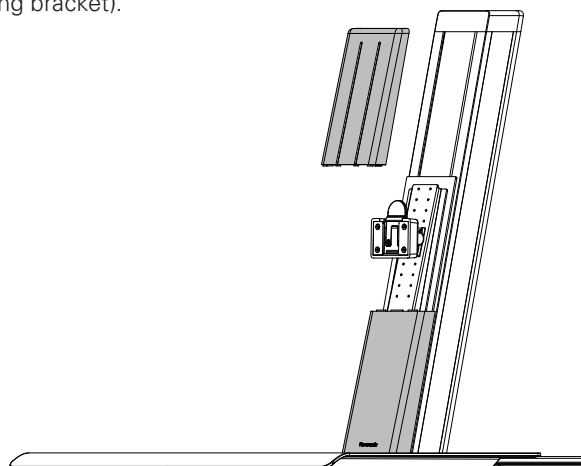

STEP 5

- Remove the top cover.

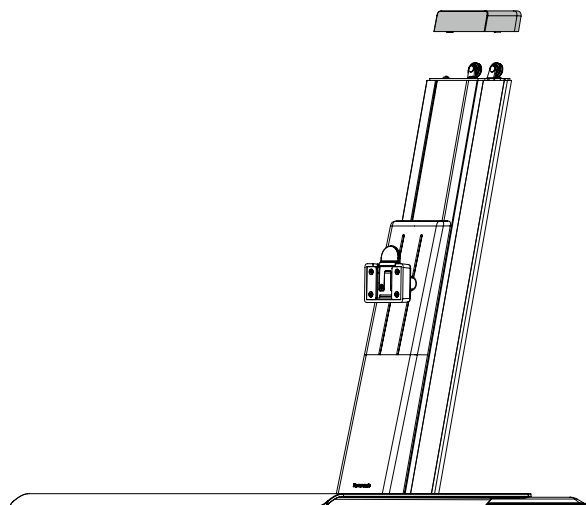

STEP 6

- Slide the right side cover upward to remove it from the post.
- Install the new side cover. (Repeat this on the other side for dual monitor)
- Place the top cover back on.

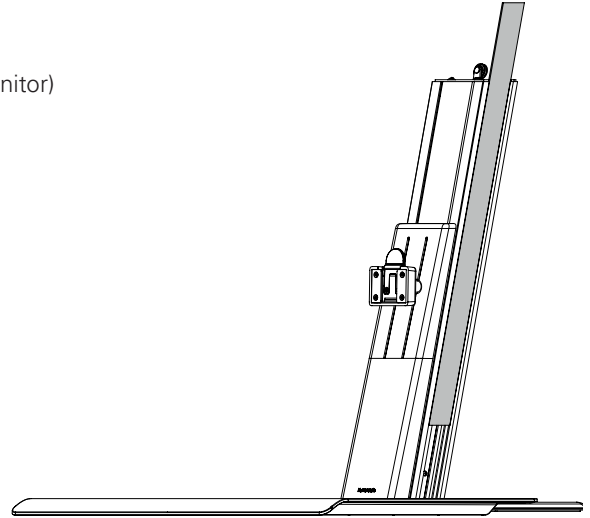

STEP 7

- Follow instructions in the “single/ dual monitor” for monitor height adjustment, counterbalance adjustment and cable installations.

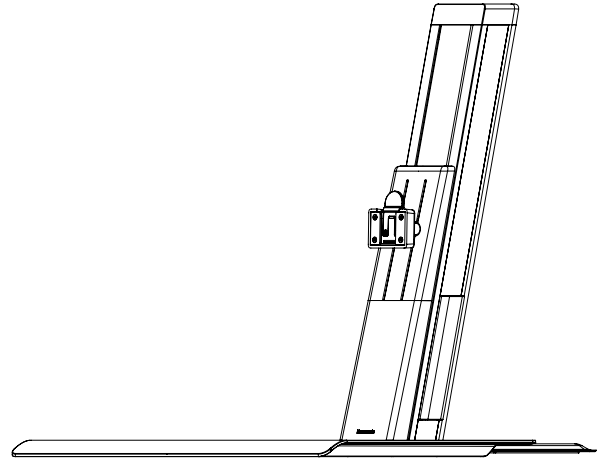



Please make an appointment to visit us at:
3401 Madison Street
Skokie, IL 60076
www.appliedergonomics.com

Call us: (847) 679-5148
Toll-free: (844) 859-9247
Fax: (847) 933-0018

Email the President directly
jmeltzer@appliedergonomics.com