

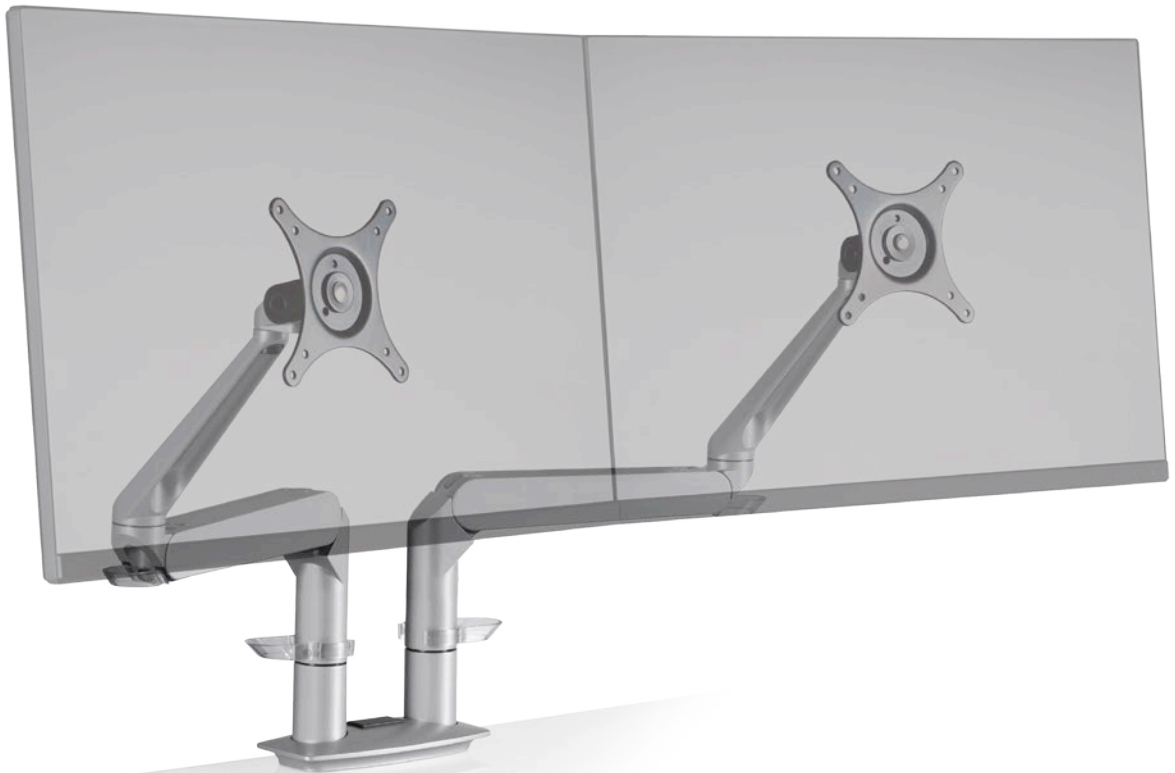

EVO® 5902

The Dual EVO® monitor mount utilizes our EVO® monitor arm in a dual monitor desk mount application. The monitor arms provide intuitive function and dual monitor rotation for easy, ergonomic viewing of both screens.



FEATURES

- Extremely flexible positioning of dual flat panel monitors.
- Ease-of-use encourages users to work with their dual monitors ergonomically.
- Rotate dual monitors for portrait or landscape viewing.
- Tension adjustment at each joint.
- Mount design includes a cable management system that routes cables beneath the monitor arm.
- Durable, quick-install VESA adapter reduces installation time.

AVAILABLE OPTIONS

5902 Supports a 1 - 15 lb (0.5 - 6.8 kg) per monitor

FINISHES

FLAT WHITE | color code: **248**

SILVER | color code: **124**

VISTA BLACK | color code: **104**



CAPABILITIES

