

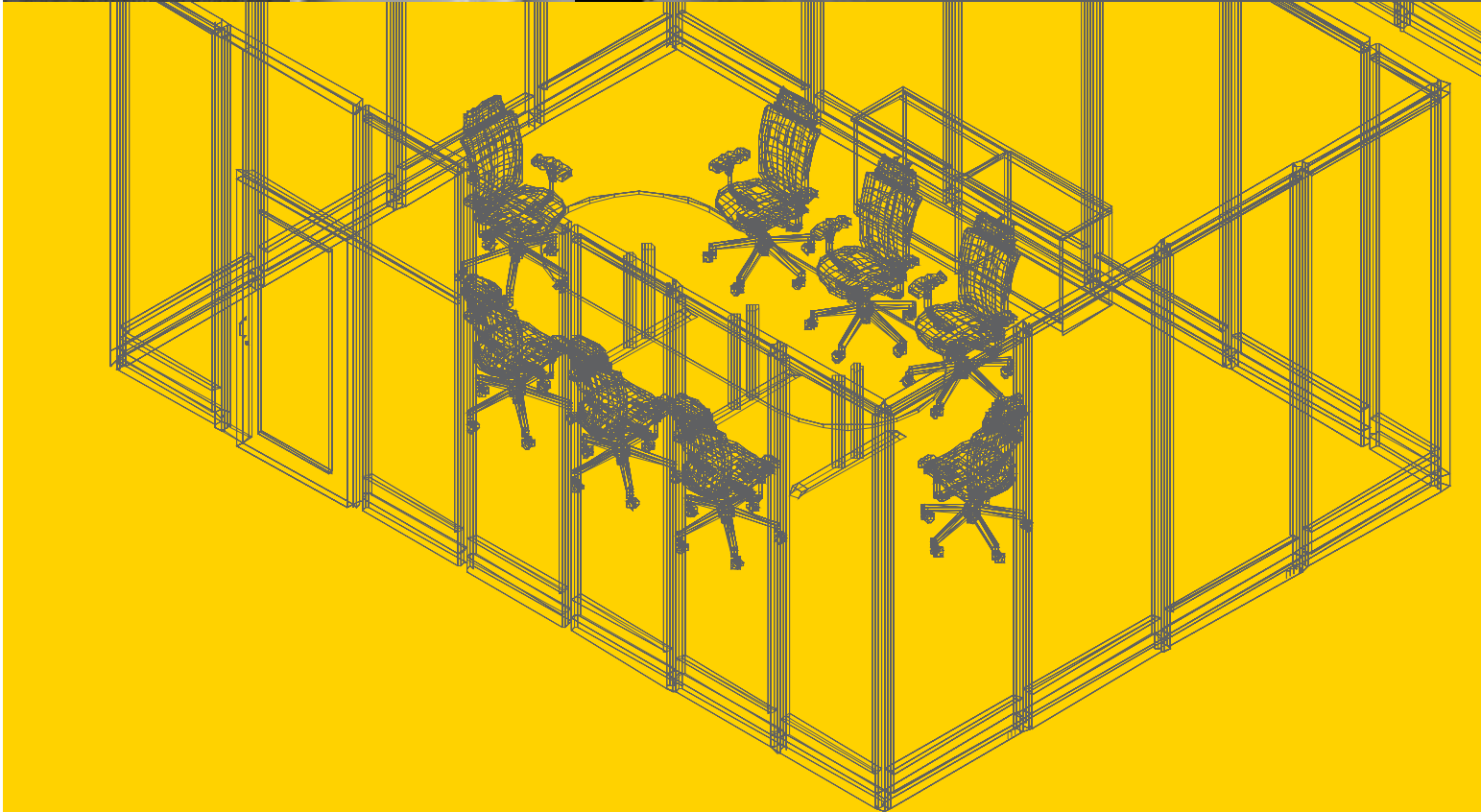

Trendway >

ARCHITECTURAL PRODUCTS  
PLANNING GUIDE



ACOUSTICAL

# FLEXIBLE

create and recreate  
spaces within spaces

more privacy  
more productivity

# FAST

less than 6 weeks  
from order to install

# SUSTAINABLE

99% reusable  
100% recyclable

# ECONOMICAL

2 trades vs. 7  
ROI in 3 years



*more than*  
Where spaces take shape.

Trendway Architectural Products take your spaces to new places – from the ground up. With tailor-made interiors that build out fast, and are inherently flexible and infinitely sustainable. With interiors solutions that move and change as your business does, TrendWall®, TrendWall® Clear and TrendWall® Flooring Solution meet the triple bottom line. All the while exceeding your standards for superior product quality and stellar customer service: All Trendway furniture is backed by industry-leading reliability – as in a 99% on-time, complete delivery record.

Walls, floors and something more: peace of mind. That's our business. And that's exactly

what you can expect from Trendway Architectural Products.



*more than*  
Reap the triple bottom line.



People, Planet, Profit  
TRENDWAY ARCHITECTURAL PRODUCTS



## Build Your Bottom Line – From the Ground Up

Great spaces start with Trendway Architectural Products. Fast, flexible, acoustical, sustainable, economical – TrendWall, TrendWall Clear and TrendWall Flooring Solution integrate with your existing interiors to create modular floorplans that look as good as they perform. And perform they will, no matter where your space takes you.

### Movable Walls That Move You

Infinitely flexible and inherently sustainable, TrendWall and TrendWall Clear provide the perfect solution for the private office. Whether you prefer stylish fabric panels or a sleek glass storefront, these movable walls will inspire your interiors and seamlessly meet your changing needs. And unlike traditional drywall, TrendWall and TrendWall Clear go up fast with fewer trades and little-to-no downtime. Time and time again.

### Raised Flooring That Stands Up

Is your cable management anything but manageable? Look no further than TrendWall Flooring Solution, a low-profile, highly-flexible floor system that not only manages your power and data but easily integrates into both new and renovated interiors. Movable flooring means no coring: TrendWall Flooring Solution moves when your people do, always with easy access to cabling through a floor panel from anywhere in your space.



## Workplace Acoustics

**Acoustics 101** | Think of acoustics as a study of balances. The only thing more destructive to worker productivity than too much noise, is not enough of it. So just how do you strike a balance between how much sound (and how much silence) is right for your space? Begin by understanding how acoustics are measured.

**Noise Reduction Coefficient (NRC)** | NRC is a single-number rating used in specification and product descriptions to show the sound-absorbing capabilities of a particular material. NRC ratings commonly are given for acoustical ceiling tiles and systems furniture panels. A material is typically not classified as a sound absorber unless it has an NRC value of at least 0.40. Porous materials, like fiberglass batt, have high NRC ratings because they allow sound waves to penetrate deeply into the material.

**Sound Transmission Class (STC)** | STC is a single number system used to rate the airborne sound transmission performance of a product like a wall, panel or ceiling. The higher the STC number, the better the product's ability to block sound transmission. A two- or three-point difference in STC ratings is insignificant because it is not detectable by the human ear. Specifiers, therefore, should not assume that a panel or partition with a higher STC rating is functionally better than one with a slightly lower rating. Like NRC, STC is a quick screening tool for comparing construction and material types, and not for design or calculation purposes.

**Noise Criteria (NC)** | NC is the measurement of background noise in specific interior environments. Because too much quiet can be as distracting as too much noise, the ideal work environment provides a healthy balance between the two. In fact, it may be necessary to create background – or white – noise using a sound masking system that emits sound vibrations that spread out into the ceiling, and filter unnoticeably into office space.

### Typical Background Noise Levels

Boardroom	NC-30
Auditorium	NC-30
Video/conference room	NC-30
Typical conference room	NC-30
Private office	NC-35-38
Open plan office	NC-38-40
Public areas	NC-40-55

### People, planet, profit.

Trendway Architectural Products are designed with the triple bottom line in mind. Which means that while you create – and recreate – the most perfect spaces on Earth, you're protecting your investment. Not to mention Mother Earth herself.

## Acoustics Planning

When mapping your floorplan, remember that there's more to great acoustics than great walls. Ceilings, flooring, HVAC, lighting, electrical – the sound quality of your space depends on it.

**Ceiling** | Look up and listen. Does your ceiling absorb sound or amplify it? For peak privacy, pair Trendway architectural walls with acoustical ceiling tiles that have a minimum STC rating of 35 and a minimum NRC rating of .65. Typically, such tiles are constructed of a high-density mineral fiber material that absorbs sound and provides a barrier to noise traveling through the tile, across the plenum and through the ceiling into adjacent offices. Batt insulation can increase the STC rating of the ceiling by one transmission class and add 10% to its NRC. Simply place batt insulation above the ceiling in the plenum adjacent to both sides of the TrendWall panel, extending the insulation 18 inches on both sides of the center line for optimum effectiveness. We recommend an R-19 factor or greater.

**Flooring** | Walk around your space, paying particular attention to high-traffic areas. Carpeting brings the best sound absorption, especially when backed by a quality pad. Adding a TrendWall Flooring Solution below the carpet, will not only make cabling and re-cabling a space a breeze, it also enhances the spaces ability to deaden sound. Keep in mind that while hardwood or ceramic tile floors may heighten aesthetics, they provide little sound absorption and actually tend to amplify sound, due to their high STC.

**HVAC** | When planning heating and cooling systems, think about both comfort and sound control. To maximize acoustics, use indirect HVAC ducts wherever possible. And instead of running supply and return air ducts directly from one side of the room to the other, branch them from the main lines located outside the space containing private offices.

**Lighting and Electrical** | Recessed fluorescent lighting and the required ventilation system create facility-wide sound transmission issues. To minimize noise, place recessed lighting fixtures as far apart as possible on opposite sides of the wall. Remember that little spaces can leak big sounds. Enhance acoustics by strategically placing electrical outlets.



### More is more.

Get the most from Trendway Architectural Products with these acoustical enhancements:

- Use solid panels instead of glazed panels wherever possible.
- Add gaskets and door sweeps for doors.
- Use batt insulation above the ceiling.
- With reveal-edge ceiling tiles, attach the crown to the ceiling grid with a Trendway-provided grid block.
- Add sound packaging to TrendWall pilasters, base, crown and wall channels.
- Minimize the use of filler panels, especially in areas where privacy is a concern.

**Speech Privacy Potential (SPP)** | SPP is the measurement of how much privacy can be achieved from one area to another. SPP is calculated by adding together the STC and NC ratings. As shown in the chart below, an SPP less than 60 provides no privacy, while an SPP of 85 provides maximum privacy. In explaining SPP, confidential speech privacy is commonly said to exist if fewer than 10% of the spoken sentences can be understood correctly by a listener in an adjacent space. The audibility of a particular sound, including speech, is dependent on how distinguishable the sound is from the continuous background noise.

### Degrees of Speech Privacy

PRIVACY RATING	SPEECH PRIVACY POTENTIAL (SPP)	DESCRIPTION OF PRIVACY
Total privacy	85	Shouting is barely audible.
Highly confidential	80	Normal levels not audible. Raised voices barely audible but not intelligible.
Excellent	75	Normal voice levels barely audible. Raised voices audible but mostly unintelligible.
Good	70	Normal voices are audible but unintelligible most of the time. Raised voices are mostly unintelligible.
Fair	65	Normal voices audible and intelligible some of the time. Raised voices are intelligible.

### Make Private Offices Really Private

Consider this equation: Combine the typical private office, with an approximate rating of NC-35, with TrendWall solid wall sections, which have a rating of STC-39, and you get an SPP rating of 74 (NC-35 plus STC-39). Likewise, TrendWall Clear has an STC rating of 36, yielding an SPP rating of 71 (NC-35 plus STC-36). So whether you choose TrendWall or TrendWall Clear, your TrendWall private office will be just that.

### Speech Privacy Ratings with TrendWall

ADJOINING AREA	STC*	+	NC	=	SPP	PRIVACY
Public Areas	39		40-45		80-85	Total Privacy
Open Plan Offices	39		38-40		78-80	Highly Confidential
Private Offices	39		35-38		75-78	Excellent

\*Assumes TrendWall sound packing option.

### Office Partition Construction and Performance Levels

OTHER CONSTRUCTION METHOD	STC
Drywall partition up to acoustical ceiling line	STC-30±
Drywall partition through acoustical ceiling 6"	STC-35±
Drywall partition with insulation, full height up to slab	STC-40-45
Multiple layered drywall with insulation, full height up to slab	STC -45+

## Engineered for Environmental Sustainability

Trendway Architectural Products are inherently sustainable. So you can expect TrendWall, TrendWall Clear and TrendWall Flooring Solution to move and change as your company does.

**Easy and Earth-Friendly** | Prefabricated and ready to install in a few simple steps, Trendway Architectural Walls go up effortlessly – and stand up to repeated reconfiguration. Non-progressive TrendWall and semi-progressive TrendWall Clear allow you to remove sections without dismantling an entire run, freeing you from the hassle with progressive systems. TrendWall even conforms to varying ceiling heights. Just cut it down or stack it up and you're ready to reinstall. When it comes to systems furniture all you need is a mounting rail to hang components of all shapes and sizes from virtually any manufacturer.

**Green From the Inside Out** | On the outside, TrendWall looks like just another panel. Yet what lies underneath is something quite revolutionary: TrendWall is made of 18% post-consumer and 28% pre-consumer recycled content. Beneath TrendWall's gypsum surfaces is an environmental layer of mineral wool insulation, which consists of slag wool. Made of 100% repurposed material, slag wool is a byproduct of steel smelting and, unlike traditional fiberglass insulation, has no outgassing. So air quality is not compromised. Even the offal gypsum board created in TrendWall manufacturing is recycled through a grinding company and then transported to farms with clay-based soil. When tilled, the recycled gypsum breaks down the clay so plants can root deeper into the soil and become more productive.

**Designed to Change** | TrendWall answers the call of environmental sustainability with a simple design that outlasts change, with maximum reusability. But that's just the beginning: All TrendWall panels and Trendway systems are completely integrated, functionally and aesthetically, meaning that they evolve and expand with you. So your new and existing installations, as well as your electrical and data, work together without creating waste or wasting your investment.

## More Than 99% Reusable

Need another compelling reason to choose Trendway Architectural Walls over drywall? Consider more than 99% reusability – a stark contrast to conventional drywall, which is not reusable. Drywall creates waste that must be shipped to landfills. And drywall is made of gypsum, which is non-biodegradable and contains lime, which breaks down clay. While this is good for agriculture, it is potentially dangerous in landfills; the breakdown of the clay protective barrier can allow seepage into ground water. In fact, many municipalities are now requiring companies to separate gypsum from construction waste so that it can be sent to landfills built especially to prevent seepage. The cost to ship gypsum to one of these specialized landfills is ever increasing. What's more, when TrendWall components eventually reach the end of their useful life, almost 100% of their content is recyclable, effectively removing it from the waste stream.

### Mover and a shaker.

TrendWall, TrendWall Clear, TrendWall Flooring Solution – all Trendway Architectural Products are reusable. Which makes them inherently sustainable and infinitely sensible for your people and the planet.

## Trendway's Sustainability Plan

Architectural products, systems, seating and storage – Trendway products are designed with the environment in mind. We see being “green” not as a destination but a journey. Along the way, we continue pursuing ways to enhance our technologies and materials to meet the evolving needs of our customers. That's why we're constantly improving our current manufacturing processes and operations by reducing waste and conserving natural resources.

### 100% Environmental Compliance

- A broad offering of 100% recycled-content fabrics, including Terratex®.
- A local “waste-to-energy” facility that generates electricity using our wood scrap.
- Programs like the “over-spray powder reclamation,” which recycles 20.05 tons annually, and “waste-to-agriculture,” which collects more than 80 tons of gypsum waste per year to recycle in soil enhancement applications. Even our sawdust is reused locally in agricultural settings.
- Adhesive materials that are No-VOC (Volatile Organic Compounds, a regulated category of air pollutants) or Low VOC (with content materials containing approximately 3% or less VOC by weight).
- Bulk packaging or blanket-wrapping of most of our products, which saves at least 45,000 boxes each year.
- Classification as a “Minor Source” for air pollutant emissions by a permit issued jointly by the Michigan Department of Environmental Quality and the United States Environmental Protection Agency (EPA).
- An extensively day lit, energy-efficient manufacturing plant that earned the EPA's “Green Lights” endorsement.
- Active membership in the West Michigan Sustainable Business Forum.

Recycling and reusing is a way of life at Trendway. In the past five years, we've recycled nearly 2.5 million pounds of fabric, cardboard, plastic, aluminum, iron and other materials. We return scrap material to its source for recycling into new products, whenever possible. What's more, our annual “Recycling and Environmental Savings Summary” reported a savings of 4,594 trees, 59,450 gallons of oil, 17,024 cubic yards of landfill space, 1,891,596 gallons of water and 16,214 pounds of air pollutants in the past year alone. Trendway has also adopted the BIFMA e3-2008 Furniture Sustainability Standard and looks forward to demonstrating how our products, processes and organization meet the criteria for level certification.



Yet our commitment to the environment doesn't stop at manufacturing. We encourage all Trendway employees to adopt environmentally safe habits and participate in stewardship efforts by:

- Awarding a monthly point bonus to each team that implements an “Environmental Improvement Initiative” in its work area.
- Using our corporate environmental theme of “Reduce – Reuse – Recycle.”
- Awarding a quarterly “Green Team Environmental Improvement Award” to the team implementing the highest valued improvements.
- Providing a 24-hour recycling collection center for employee household wastes.

### Take the LEED.

Trendway Architectural Products carry a high probability of contributing to LEED points to your project certification. Learn more at [www.trendway.com/green](http://www.trendway.com/green).

## Flex Your Space and Your Spending

Expand, downsize, renovate, relocate – as your business evolves, Trendway Architectural Products respond. From initial installation to multiple reconfigurations, you can easily change your floorplan without the chaos or cost of new construction.

**Rapid Specification** | Whether you create your own specification through 20-20 CAP Studio or have Trendway handle it for you, the deliverable is a complete, finished floorplan that's ready for occupancy.

**Simple Reconfiguration** | When it comes time to revamp your space, simply send us your new floorplan and specifications (and make reference to your original project drawings). We'll then develop a plan that maximizes the reuse of your existing TrendWall, TrendWall Clear and/or TrendWall Flooring Solution components – protecting your investment in Trendway Architectural Products.

**Smarter Investment** | Fewer components mean fewer trades – fewer hassles, less downtime, and little-to-no dollars for reconfiguration or waste disposal, since you're not tearing down walls or re-coring floors.

CONSTRUCTION TYPE	MATERIALS VS. LABOR COST	TYPICAL REUSABILITY
Trendway Architectural Products	80%   20%	99%
Demountable Walls	60%   40%	30-40%
Conventional Drywall	45%   55%	0-10%

**Tax Considerations** | Trendway Architectural Products are classified as tangible property and therefore qualify for the Modified Accelerated Recovery System (MACRS), a benefit that allows you to depreciate them over seven years – a significant difference, especially with TrendWall versus drywall, which depreciates in 39 years. (Be sure to ask your tax consultant for a final determination of your tax breaks with Trendway Architectural Products.)

**Low Life Cycle Costs** | Invest in Trendway Architectural Products and you invest in a future filled with the flexibility and the financial smarts of reusable materials, so your walls can take the shape of your business without breaking your bottom line.

**Change x Reuse = ROI** | Trendway Architectural Products are built to build the triple bottom line. With an annual churn of approximately 20%, you can expect 100% ROI in just three years. Moving your walls in five years or less? Get complete ROI when you move TrendWall or TrendWall Clear just once. Not to mention significant savings with fewer trades and virtually no disposal costs, since you're not tearing down walls.

**Less Downtime** | Trendway Architectural Products let you configure and reconfigure space simply and efficiently. Let alone reduce tenant improvement time.

**Privacy = Productivity = Profits** | Acoustical privacy – yet another benefit of Trendway Architectural Products – leads to all-around productivity, and a healthier bottom line and a more pleasant work environment.

### Move more, save more.

With 99% reusability, TrendWall and TrendWall Clear leave little waste. Which leaves you with only one predicament: Just how will you spend all that money you're going to save in disposal costs?

## 3BL in 3 Years

Invest in Trendway Architectural Walls and reap the rewards of meeting the triple bottom line in just three years.

Assume you borrowed the difference in cost between conventional drywall construction and TrendWall. (See yellow bar in chart below.) Based on our analysis of accelerated depreciation and churn rates, you would pay off your loan in less than two years and realize a cumulative savings of almost \$200,000 by year seven. Our calculation is based on the material and labor differences between drywall and TrendWall and does not include the cost savings realized in the installation and repair of ceiling and floors or the impact to worker productivity.

*Note: This analysis is based on 500' of solid partitions, 10 doors and 2' sidelites adjacent to the doorways. This project consists of 8' high vinyl covered walls with basic trim and doors. Conventional drywall construction costs are based on national averages. Ask your Trendway Architectural Products dealer for a customized financial analysis that reflects your business.*

### CUMULATIVE ANNUAL CASH FLOWS (7 YEAR MACRS)

#### TrendWall versus Drywall

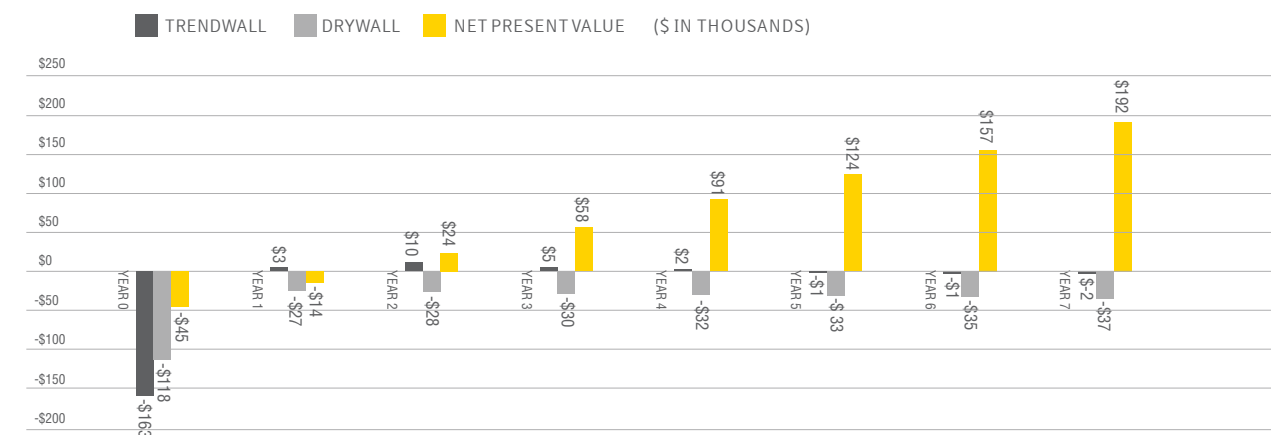

#### Trendway Architectural Products versus Conventional Construction

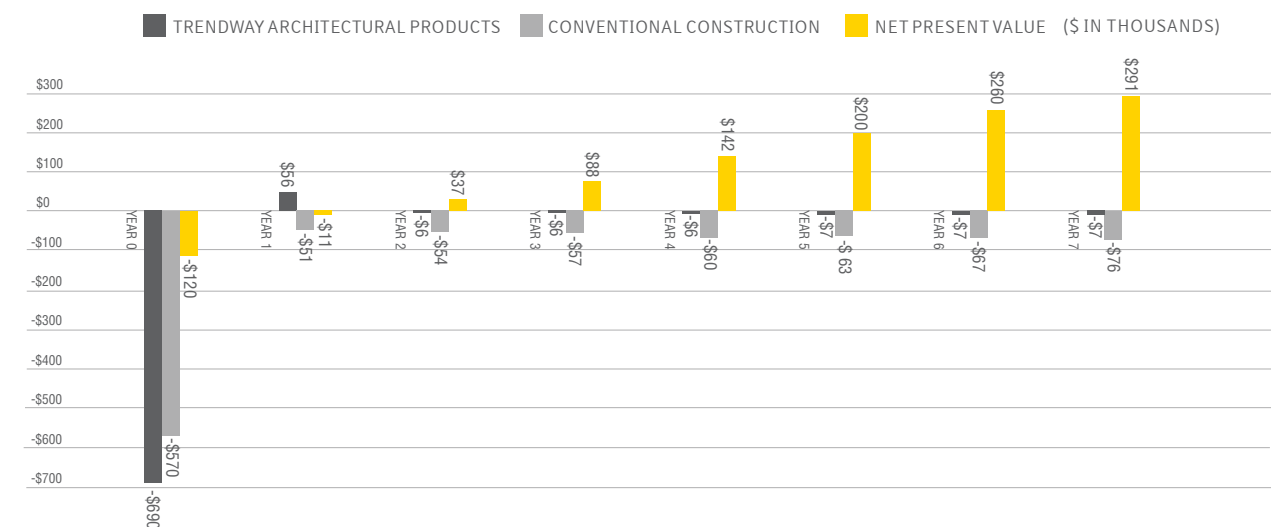

## Fast, Flexible – For Now and Later

TrendWall and TrendWall Clear install and reconfigure with ease. Which makes them easy on your bottom line. Consider the initial material and labor costs associated with conventional drywall and TrendWall Architectural Walls: While drywall provides lower initial construction cost, it also demands that you deal with the downtime, mess and infl

INITIAL COST (PER LINEAL FOOT)  
TrendWall versus Drywall

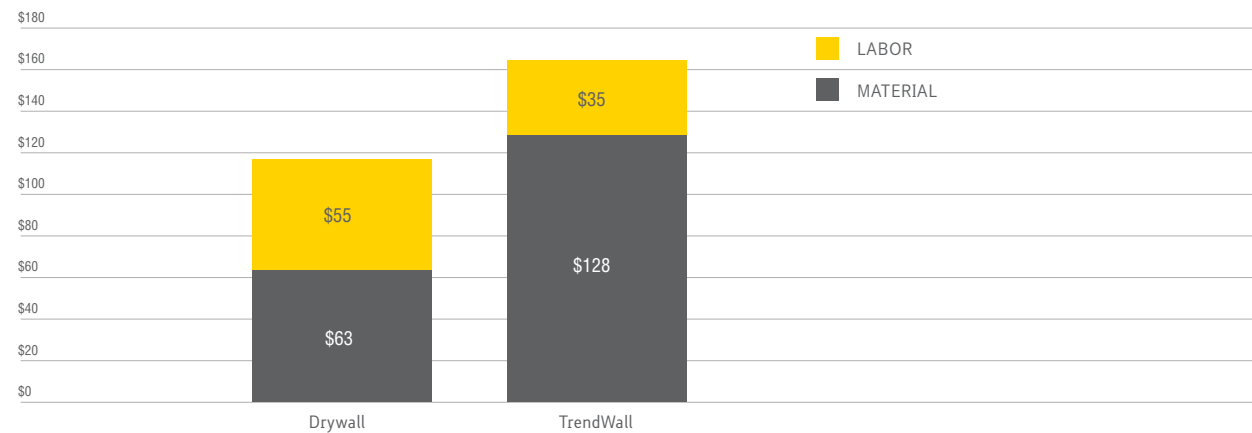

INITIAL COST (PER SQUARE FOOT)  
Trendway Architectural Products versus Conventional Construction

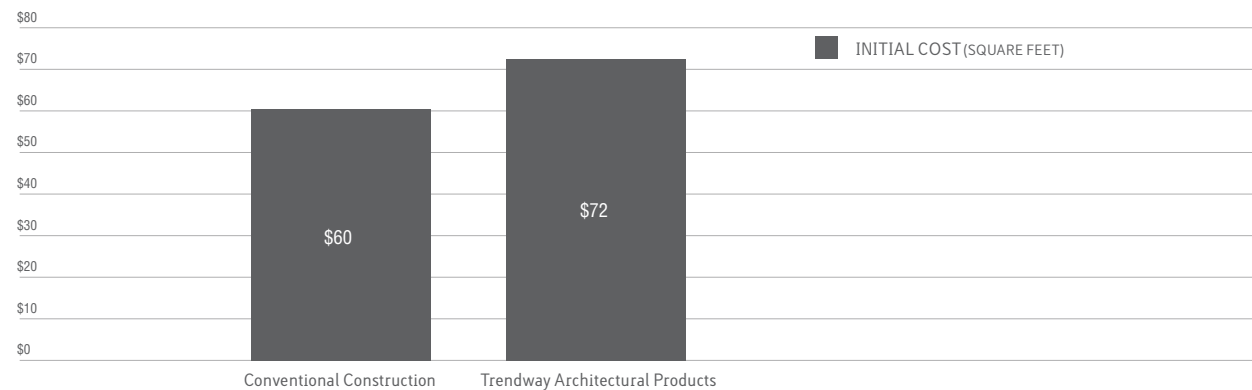

## Change is Good

With national churn rates averaging more than 20%, there's no time like now to find new ways to organize your office space. (And just think: More churn means more savings.) The reusability of TrendWall and TrendWall Clear significantly reduces your annualized facility costs.

*Note: This analysis utilizes a national average for workplace churn. Ask your Trendway Architectural Products dealer for a customized financial analysis that reflects your business.*

LIFECYCLE OWNERSHIP COSTS (PER LINEAL FOOT)  
TrendWall versus Drywall



LIFECYCLE OWNERSHIP COSTS (PER SQUARE FOOT)  
Trendway Architectural Products versus Conventional Construction

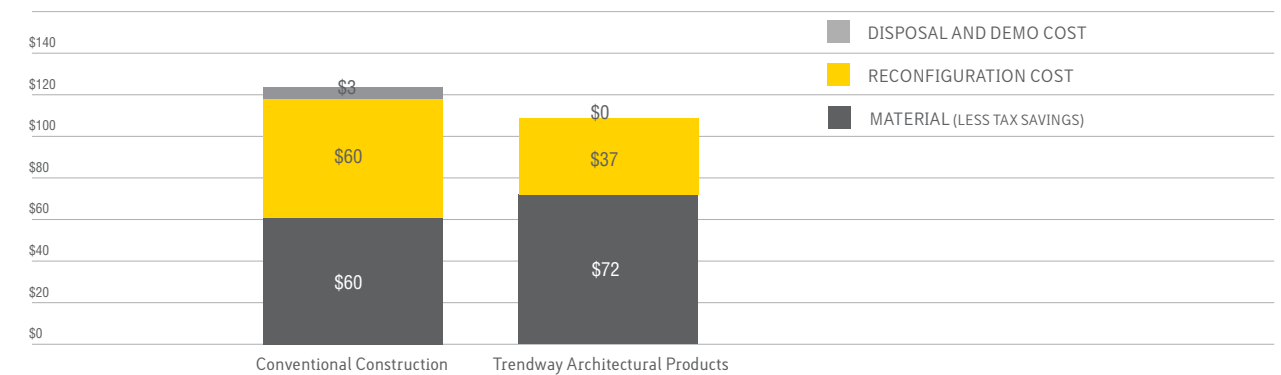

### 3BL in 3.

Trendway Architectural Walls build the triple bottom line. With an annual churn of approximately 20%, you can expect 100% ROI in just three years. Moving your walls in five years or less? Get complete ROI when you move TrendWall or TrendWall Clear just once.

*more than*  
See the plan.



## TrendWall and TrendWall Clear

ARCHITECTURAL WALLS



## Which Wall Works Best For You?

### Conventional Drywall Construction

Putting up walls in an empty space with a static floorplan? Then conventional drywall construction could be your best choice. Drywall is the most common (and perhaps most understood) type of construction. Built onsite, drywall typically provides the lowest initial cost yet the longest installation time – framers, hangers, finishers, need we go on? Good project management is required to ensure your walls are completed on time and within budget.

### Architectural Walls

How are architectural walls different from drywall? They're fast and flexible, installing with fewer trades and little mess. TrendWall is a unitized, non-progressive panel that's manufactured offsite, while TrendWall Clear is a semi-progressive, built onsite architectural storefront. Both types of Trendway Architectural Walls are a snap to install and simply reconfigure with minimal labor, material loss (more than 99% reusability) and downtime.

#### Breaking Down Wall Types

CONSTRUCTION TYPE	INSTALLATION	REUSABILITY	ROI
Drywall	<ul style="list-style-type: none"> <li>Fabricated onsite</li> <li>Time-intensive, messy installation</li> </ul>	<ul style="list-style-type: none"> <li>Static and not reusable</li> </ul>	<ul style="list-style-type: none"> <li>No ROI</li> </ul>
Demountable Walls	<ul style="list-style-type: none"> <li>Fabricated onsite</li> <li>Fast, clean installation</li> <li>Typically a progressive system – less flexible</li> </ul>	<ul style="list-style-type: none"> <li>Movable yet complex with many parts and pieces – component damage limits reusability</li> </ul>	<ul style="list-style-type: none"> <li>Low ROI</li> </ul>
TrendWall high Architectural Walls	<ul style="list-style-type: none"> <li>Fabricated offsite, engineered to order</li> <li>Fast, clean installation – two trades do the job in days, not months</li> </ul>	<ul style="list-style-type: none"> <li>Movable and very flexible – unitized panels look and act like systems furniture</li> <li>Non-progressive system – utmost flexibility</li> </ul>	<ul style="list-style-type: none"> <li>Moderate to ROI, depending upon churn</li> </ul>
TrendWall Clear high Architectural Walls churn	<ul style="list-style-type: none"> <li>Assembled onsite, engineered to order</li> <li>Fast, clean installation – two trades do the job in days, not months</li> </ul>	<ul style="list-style-type: none"> <li>Movable and reusable</li> <li>The ultimate architectural storefront</li> <li>Semi-progressive system – very flexible</li> </ul>	<ul style="list-style-type: none"> <li>Moderate to ROI, depending upon</li> </ul>

## Trendway Architectural Walls Planning (Think: Weeks Not Months)

### 20-20 CAP Studio Specified

Trendway Architectural Wall components are fully supported for planning in CAD environments. 20-20 CAP Studio lets you specify TrendWall and TrendWall Clear just like you specify systems furniture.

### Trendway Specified

- 1 Send us your floorplan in your format of choice – CAD drawing, architectural rendering, loose sketches, you name it – complete with measurements and a list of your office needs like furniture components, data communications and so forth.
- 2 We engineer TrendWall to your specifications, create a floorplan – as a layer inside your AutoCAD file or as an original drawing – and send it to you with a quote in less than one week.
- 3 Together, we work through revisions so the floorplan blueprint meets your exact specifications.
- 4 You approve your final floorplan blueprint and place your order.
- 5 We build and ship your order, and install around your schedule, all within six weeks.

### 100% Support

Trendway dealers are trained professionals, so they know how to get the job done on time, on budget and always on target with your architectural plans. From planning and specifying to installation and reconfiguration, your dealer will be your consistent link to Trendway – and a constant partner throughout the planning process.

#### Count on your Trendway Architectural Products dealer to:

- Inspect your site.
- Take accurate measurements.
- Provide a customized financial analysis.
- Help maximize your floorplan.
- Assist with your electrical and data planning.
- Tackle the finishing touches like trim, doors, closets and components.

### Easy Reconfiguration

When it comes time to revamp your space, simply send us your new floorplan and specifications (and make reference to your original project drawings). We'll then develop a plan that maximizes the reuse of your existing TrendWall and TrendWall Clear components, which protects your investment in architectural walls.



# TrendWall Components

Forget taping, mudding and sanding: TrendWall is an easy, flexible wall with just four components.

1. Framing Elements
2. Panels / Doors
3. Finish and Trim
4. Power and Data

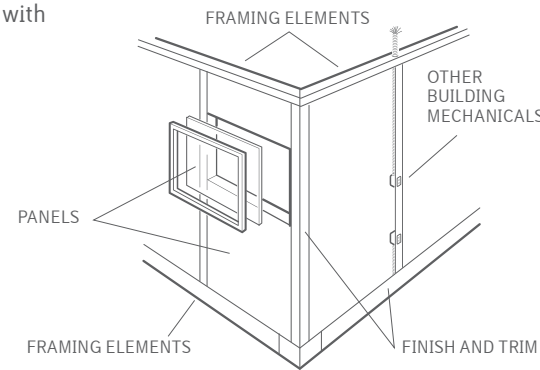

## Framing Elements

**Crown** | Made of 18-gauge roll-formed steel, the crown is the U-shaped ceiling channel that holds each panel in place. The crown can be screwed or clipped to the ceiling grid with caddy clips that hold the crown without defacing the grid itself.

**Floor Plate** | The floor plate is made of 20-gauge roll-formed steel channels that align and attach the base of each panel to the floor. And because TrendWall installs above flooring, there's no need to screw into the foundation. Carpet grippers or double-sided tape get the job done, and leave your flooring and ceilings hole-free.

**Wall Channel** | The vertical wall channel accommodates cutting a filler panel down to size to make way for mullions, moldings or other dimensional variations. The filler panel simply slides into the wall channel for a finished look.

## Panels

**Solid Panels** | Solid panels are fabric or vinyl clad 3/8" gypsum surface, available in a wide variety of fabrics, plus smooth or textured vinyl, as well as Customer's Own Material (COM). Panels also can be specified with vinyl on one side and fabric on the other – an application suited for an executive office that shares a wall with warehouse operations, for example. All visible metal surfaces on the panel are finished with powder-coated epoxy. Painted surfaces are offered in an array of trim colors. See the Surface Material Color Legend for fabric and color options.

**Glazed Panels** | Glazed panels consist of the frame in which to insert glass. These panels are roll-formed steel frames with 22-gauge vertical and horizontal glass rails and dual durometer vinyl glass retainers that hold a 1/4"-thick sheet of tempered safety glass or other approved glazing materials. You can choose to have glass provided by Trendway or a local glassier (we provide a complete glass schedule on all orders that ship without glass).



**Filler Panels** | Filler panels are placed at the end of a panel run that meets a fixed wall, in order to accommodate window mullions and moldings, as well as compensate for uneven wall conditions and interface with irregular shapes. Available in 6" to 48" widths in 6" increments, filler panels have a steel side rail on one end only and an expanded polystyrene core, allowing them to be cut to fit in the field. They include a wall channel to provide a clean finish. Filler panels are figured automatically into a job as required but also may be ordered individually. Ceiling filler panels are constructed identically to the corresponding panel below them.

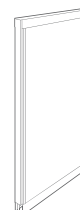

**Panel Height** | TrendWall panels are built in 1/8" increments from 7'2" to 10' high. Need more height? Simply add ceiling panels for an additional 1' to 4' in height (note: the minimum ceiling filler panel is 1'). What's more, crown filler blocks also can create an additional 1" to 12" in height, but they cannot be used with ceiling panels. To compensate for irregularities in the floor or ceiling, TrendWall panels have an adjustable base that accommodates 3/4" up or down for a total 1-1/2" adjustment.

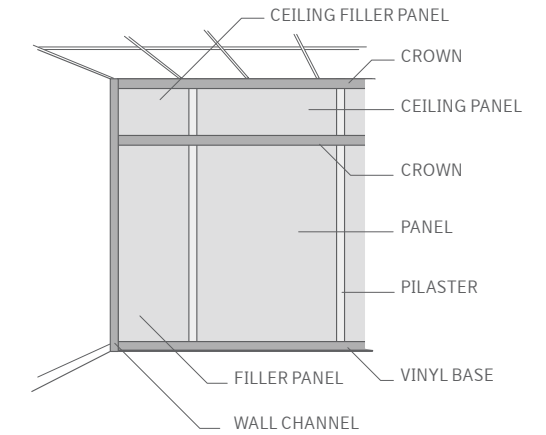
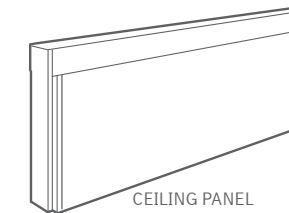

**Panel Width** | TrendWall panels are available in 1/8" increments from 6" to 4' wide. Our most cost-efficient panel is 4' wide. Unless you specify otherwise, we'll build yours at this affordable width.

## Doors

**Door Sections** | TrendWall Door Sections are available with a factory pre-hung door, or without a door for projects in which doors will be purchased locally. Door sections include anchor blocks that penetrate the floor and secure hinges and strikes so they don't move over time. As with TrendWall panels, you have the option of door sections with vinyl on one side and fabric on the other. Door section transoms can be specified solid, glazed or with painted metal louver. Headers may be fabric covered for single and double doors, and vinyl covered only for bi-fold doors. Side panels are vinyl or fabric covered.

**Door Section Heights** - Available in a variety of sizes to accommodate openings from 7'2" to 10' in height.

- Standard Door Section Width – 48" (including 8" side panel).
- Double Door Section Width – 72" and 84".
- Nominal Door Section Width – 40" (no side panel).
- Bi-Fold Door Section Width – 48", 60" and 72".
- Sliding Door Section Width – 48".

**Door Panels** | TrendWall door panels are vinyl faced and available in solid core or hollow core wood construction. Single doors are pre-hung in frames that include a steel jamb and transom, while double and bi-fold doors are shipped knocked down. All TrendWall doors comply with ADA door clearance requirements. Doors can be engineered to order with a wide range of options including:

- Door Styles – Single, Sliding (single), Double and Bi-fold.
- Door Height – 6'8" or 7'.
- Door Swing – Right-hand or Left-hand.
- Door Lite – Flush (with or without Louver), Window Lite (with or without Louver), Vision Lite (with or without Louver) or Full. (Sliding door available flush or full lite only; Bi-fold door available flush only.)

### Count on recycled coverings.

Trendway purchases fabrics from suppliers with exceptional environmental policies. So you can cover TrendWall panels in a multitude of 100% recycled content fabrics, including Terratex®.

**Standard Single Door Panels** | Standard single doors are 3' wide by 6'8" or 7' high by 1-3/4" thick. Specify left-hand or right-hand swing. The 18-gauge roll-formed steel jambs must be mechanically fastened to the floor. Want windows? You can specify them in virtually any size and shape.

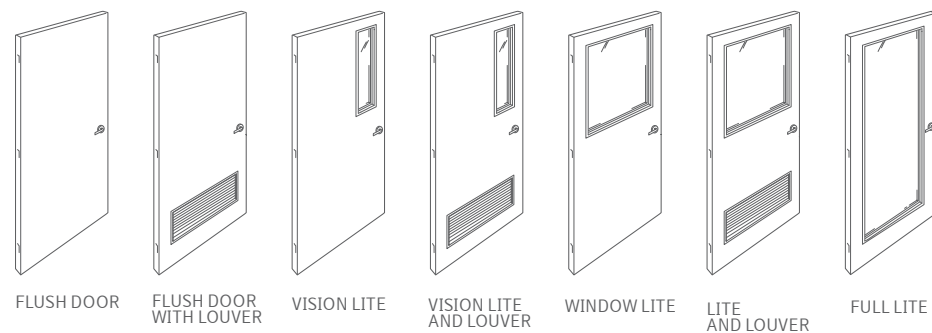

**Double Door Panels** | Double doors feature one active door and one inactive door, which is kept closed by a latch on the edge near the top and bottom. Unlocking the latch allows both doors to open, creating a 6' wide entrance. Field assembly is required.

**Bi-fold Door Panels** | Ideal for storage, bi-fold doors are double doors hinged in the middle to fold out of the way as they open. Field assembly is required.

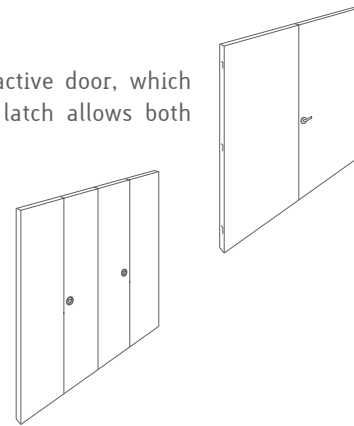

## Finish and Trim

Pilasters are the finished covers designed to snap into place between the panels to conceal the panel connectors and wiring. They come in the same height as panels, ranging from 7'2" to 10' and from 1' to 4' for ceiling fillers. Panels include two matching pilasters, one for each side of the panel. Pilasters are available with optional punchouts for switches, duplex receptacles and data communications.

**Standard Pilasters** | Standard pilasters fit between the panels, exposing the panel side rails.

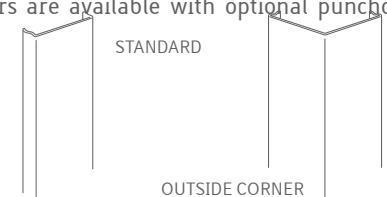

**Enhanced Pilasters** | Designed to minimize the vertical line, enhanced pilasters cover panel side rails.

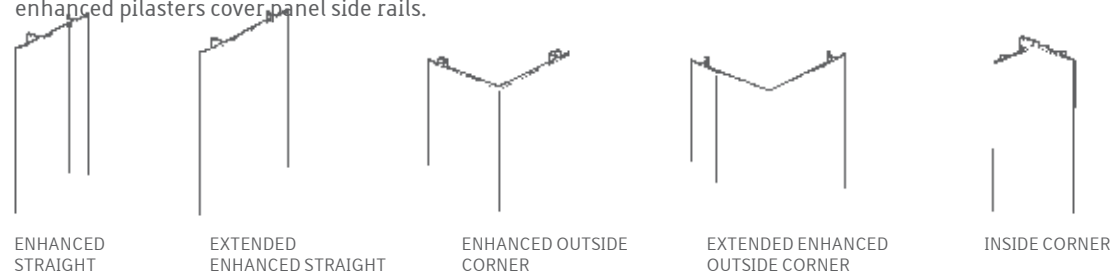

**Punchout Pilasters** | Pilaster punchouts are used with data communications and electrical.

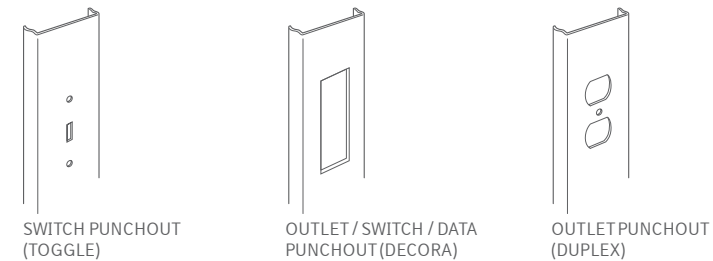

**Base** | Like pilasters, bases enhance the aesthetics of TrendWall. Made of extruded vinyl, the base creates a finished look at the bottom of the panel.

**Panel Connectors** | Panel connectors do just that – connect panels. Standard connectors are made for straight and corner connections.

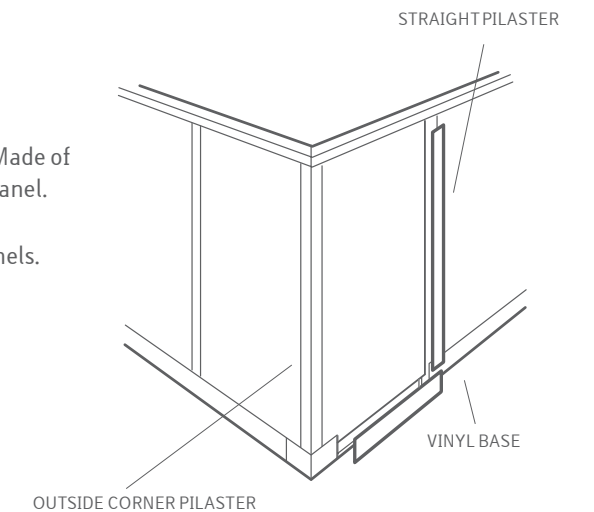
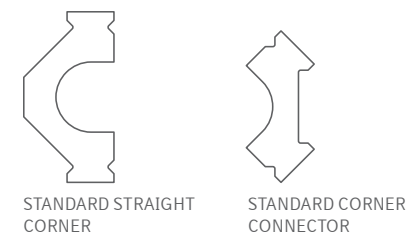

**Finished End Kits** | Finished End Kits are used to create an end of run that does not abut an existing building element. They can be used in pairs to create archways. One kit includes a painted finished end, one crown cap and two vinyl door base ends.

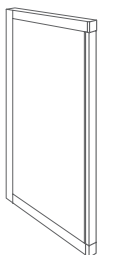

## Termination and Integration

TrendWall can be terminated into existing building elements by using a filler panel and a wall channel. The width of filler panel will be determined by the building wall cross section. TrendWall also can be integrated into TrendWall Clear via a vertical Transition Post.

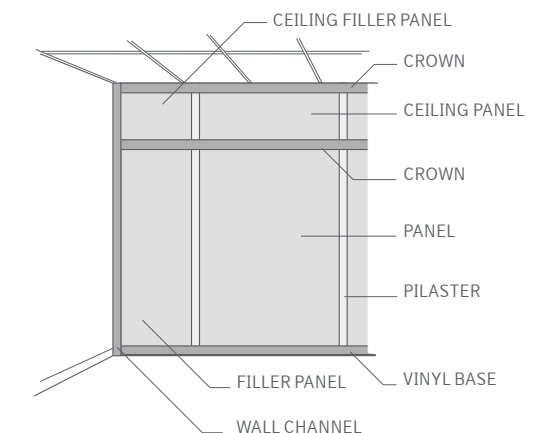
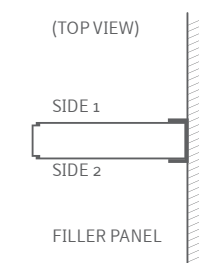

## Power and Data

### Modular Power | Endless pathways, easy access.

The TrendWall electrical system provides virtually endless pathways for accessing building power and supplying electrical power where and when it's needed. From data communications and thermostats to fire strobes and security systems, TrendWall has lay-in capability between and below panels. This makes electrical installation easy and efficient. With TrendWall, you don't need to be a mechanic to access building mechanicals. Simply snap pilasters and bases off with your hands.

- Panels are 2-3/4" thick and have a 2-3/4" by 2" minimum space between them, making way for electrical and data communication mounting.
- Panel bases have a 2-3/4" by 3" space designed for distribution of electrical and communication routing for continuous lay-in of wiring and cables.

What's more, TrendWall complies with CAT 5, 6 and 7 cabling specifications, as well as fiber optic specifications. If you're hardwiring the electrical, be sure to consult your local inspector for code requirements.

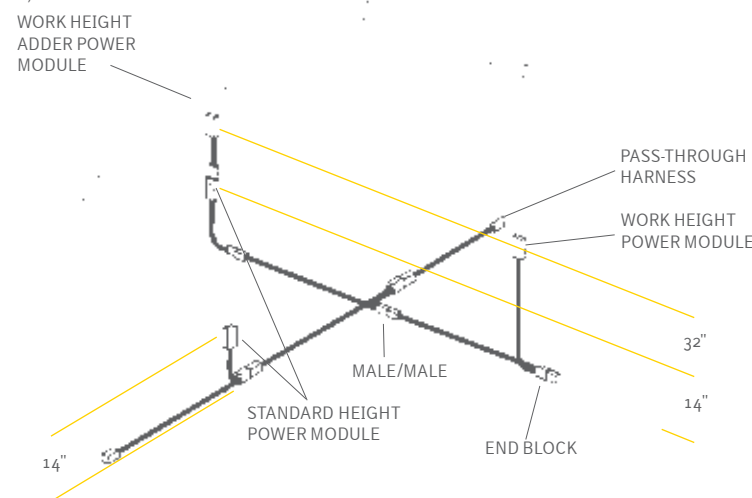

### Power Feeds | Bring power to a TrendWall section.

**CEILING FEED |** The ceiling feed brings power from the ceiling to the base of the TrendWall section and plugs into the power module or pass-through harness, which runs in the pilaster.

**END MOUNT BASE FEED |** The end mount base feed brings power from the floor, wall or column and plugs into the power module or pass-through harness.

**PASS-THROUGH HARNESSES |** The pass-through harnesses distribute power through the base of the TrendWall panel to each power module.



**MALE/MALE HARNESS |** The male/male harness distributes power through the TrendWall base.



### Power Modules | Distribute power within a TrendWall section.

**STANDARD HEIGHT POWER MODULE |** The standard height power module locates duplexes approximately 14" from the floor and is specified anywhere a duplex will be located at standard wall height.

**WORK HEIGHT POWER MODULE |** The work height power module locates duplexes approximately 32" from the floor and must be specified anywhere a duplex will be located above the work surface and there will not be a standard height power module in the same pilaster.

**WORK HEIGHT ADDER POWER MODULE |** The work height adder power module provides duplexes at work surface height when a standard height power module is installed in the same pilaster. The work height adder module allows for the installation of duplexes (one on each side).

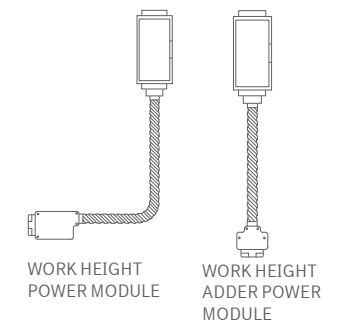

**END BLOCK |** One end block is required for every run of electrical parts. The end block connects the final power module to the pass-through harnesses.

**HARDWIRE ELECTRICAL |** Electrical box for hardwire and switch applications:

- Appleton M1-250 (Available to order from Trendway.)
- Bowers 1-MBS
- Raco 690
- Steel City GW-125-C
- Or equivalent

Electrical for the modular system:

- 8-Wire, 4-circuit, 15-amp per circuit modular electrical system.

END BLOCK

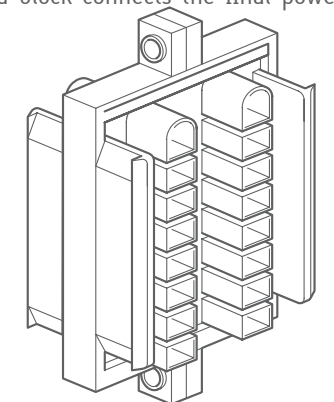

### Component Mounting | Hanging systems furniture on TrendWall.

TrendWall is compatible with Trendway systems components - and those of other manufacturers, too - with a design that's pre-engineered and ready for furniture installation. Unlike drywall construction and demountable walls which typically require extra backing, not to mention extra time and cost, Trendway offers integrated mounting options for attaching systems components to TrendWall:

- Fits the panel-to-panel in-line connection, 8' to 10' high, with component pre-slotting to 84" high.
- Intended only for floor-to-ceiling panels.
- Not to be used with ceiling panels or crown filler block.

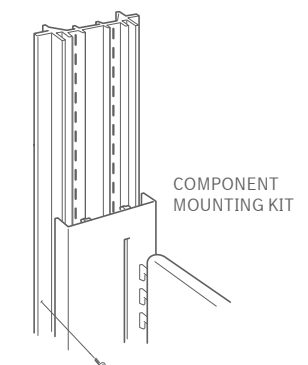

# TrendWall Installation

## STEP 1: Crown and Floor Plate

### Crown

- Working from your TrendWall floorplan, use tape or chalk to create a layout on the ceiling.
- Attach the crown with screws or optional caddy clips.

### Floor Plate

- Drop plumb lines from the crown to the floor.
- Use tape or a chalk line to create a panel layout duplicating the layout of the crown.  
(Hint: Baby powder in the chalk line makes cleaning up easy.)
- Secure the floor plates by pressing firmly while using carpet grippers or double-sided tape, no need to cut carpeting or flooring.

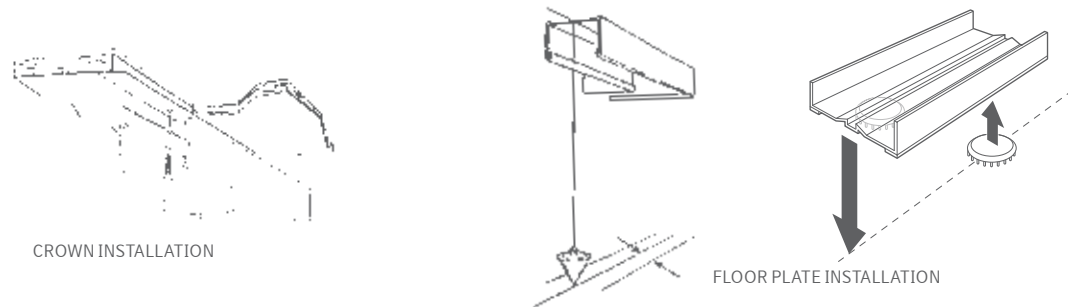

## STEP 2: Panels, Glazing and Electrical

### Panels

- Lift the panels into the crown.
- Fit the panel into the floor plates, adjusting leveling glides to compensate for irregularities in the floor and/or ceiling plus or minus 3/4" or a total adjustment range of 1-1/2".
- Continue setting and leveling panels to create a parallel surface.
- Connect adjacent panels with panel connectors. (Note: Straight connectors connect panels in a run. Corner connectors connect panels at a right angle, and special angle conditions can be accommodated.)

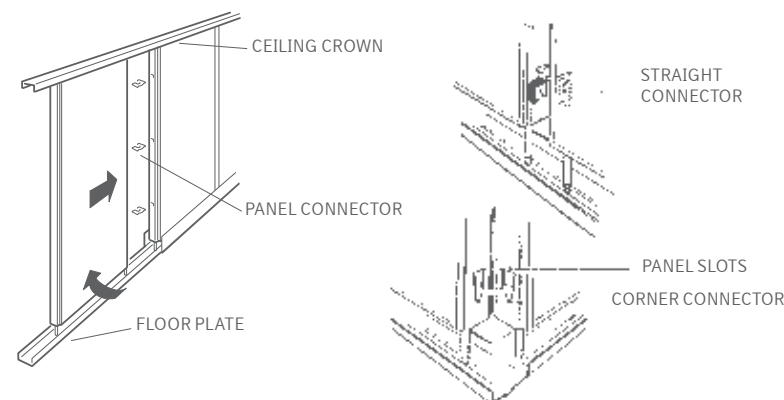

### Glazing

- Press the glass into the glazed panel against the factory-installed female molding.
- Use a mallet and wood block to tap the male moldings into place and secure the glass.

### Electrical

- Lay wiring into the horizontal and vertical spaces. Horizontal spaces are located between the bottom of the panel and the floor plate. Vertical spaces are found where panels connect. Be sure to consult your architect or building inspector for local code requirements.
- Position knockouts for outlets, switches, thermostats or other building mechanicals on the vertical pilaster.
- Bring power into the modular electrical system with the ceiling feed and the end mount base feed. The feeds connect to pass-through harnesses, which distribute power through the base of the panels to each power module location.
- Power modules are secured to the panel frames by an integral bracket and self-drilling screws. TrendWall accommodates two-, three- and four-way power routing conditions.

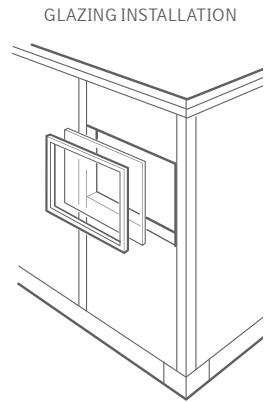

## STEP 3: Finish Carpentry

### Pilasters

- Attach the pilasters between the panels to conceal the connectors and wiring.

### Bases

- Slide the bases onto the floor plate to create a clean visual line.
- Snap in the base end caps at the end of each panel run and door section.

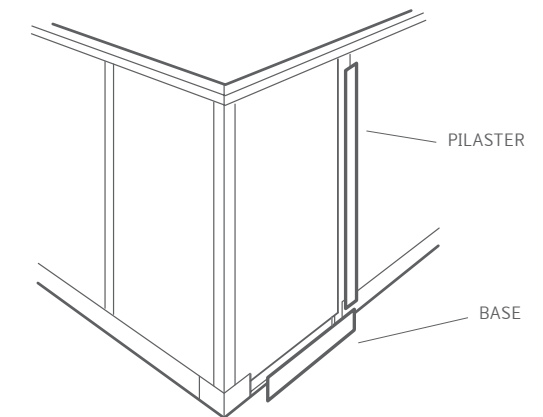

### Low impact solution.

TrendWall installs above the floor and below the grid. This makes quick work of installing building elements like drop ceilings and carpeting. It also saves you labor and material costs right now and when you reconfigure (hint: no need to patch drywall or flooring).

# TrendWall Clear Components

High-end meets low downtime: TrendWall Clear delivers a sophisticated aesthetic in a simple wall with just four components.

1. Framing Elements
2. Inserts
3. Doors
4. Power and Data

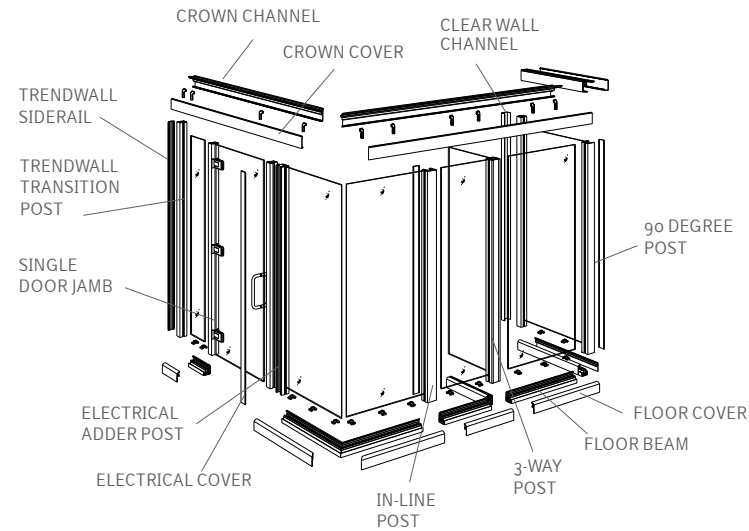

## Framing Elements

**Beams** | Upper and lower beam assemblies include all structural and decorative trim pieces, as well as all required connectors. All beam covers are made from the highest-grade extruded aluminum and are 3 1/4" thick. All beam covers are field-cut to ensure the best possible fit and finish. Upper beams are 4-1/2" tall and mount to either a hard ceiling or a drop-ceiling grid. Lower beams rest on the finished floor and vary between 4" and 5" tall, depending on the extension required to accommodate any floor run out. The system can accommodate up to 2" of floor run out with single sized glass. Beams can be specified in Satin Etch (brushed aluminum look) or

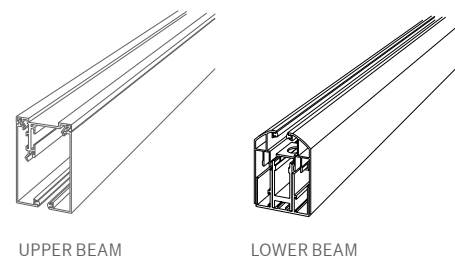

**Vertical Posts** | Vertical Posts include In-Line Posts, 3-Way Posts, 90 Degree Posts, Transition Posts (Hardwall and TrendWall) and Electrical Adder Posts. All Posts are 3-1/4" thick and are designed with vertical wire management capability (except Transition Posts), and come with an integral snap access cover. Vertical Posts can be used aesthetically or functionally. Like Beams, Vertical Posts can be specified in Satin Etch (brushed aluminum look) or another of Trendway's many powder coat finishes.

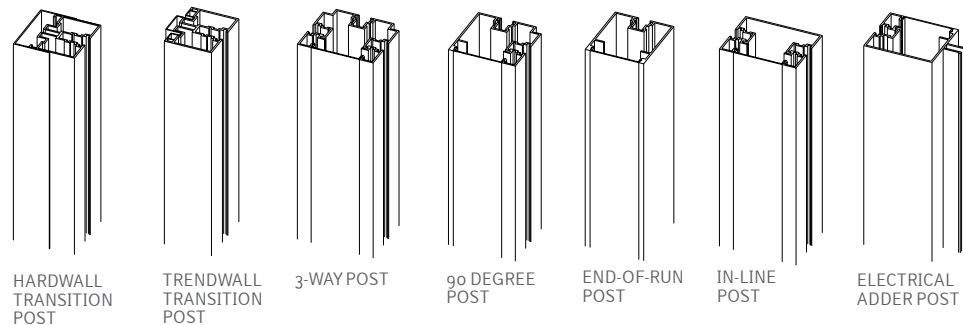

## Inserts

TrendWall Clear inserts are 1/2" tempered glass that can be specified to any width (12-36") in 1/8" increments. They come standard in three distinct glazing color options: Clear, Low Iron (colorless) and Frost. Clear is standard tempered glass that has a slight hint of color. Low Iron tempered glass is as colorless as glass can get. Frost gives visual privacy, while allowing some light transfer between spaces.

## Doors

TrendWall Clear offers several architectural door options that differentiate it from other systems.

**Pivot Doors** | Full 1/2" tempered glass Pivot Doors are specified at full height and have three pull options.

**Sliding Doors** | Full framed 1-3/4" Sliding Doors are single-opening, full height sliding barn doors with two pull options.

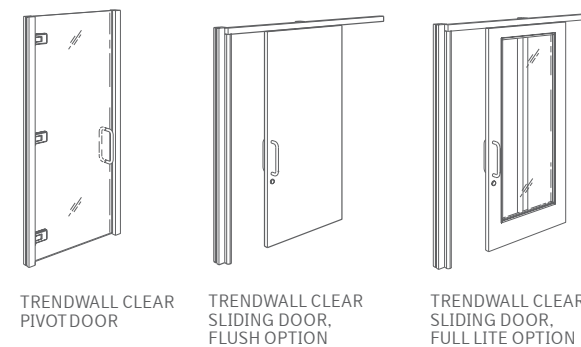

HINGE

PIVOT DOOR TO ELECTRICAL ADDER

### See things Clear-ly.

A sleek storefront that performs as good as it looks, this floor-to-ceiling wall blends practical features with polished aesthetics.

Not to mention tool-free glass mounting detail. See why it's the clear choice for your private office.

## Termination and Integration

TrendWall Clear can be terminated into existing building elements in one of two ways: Using a TrendWall Clear Hardwall Transition Post which allows 1" of float (FIG A) or into a TrendWall filler panel (FIG B). Remember that TrendWall is 2-3/4" thick, so that when bringing the two systems together, there will be a 1/4" step on both sides of the system (FIG C).

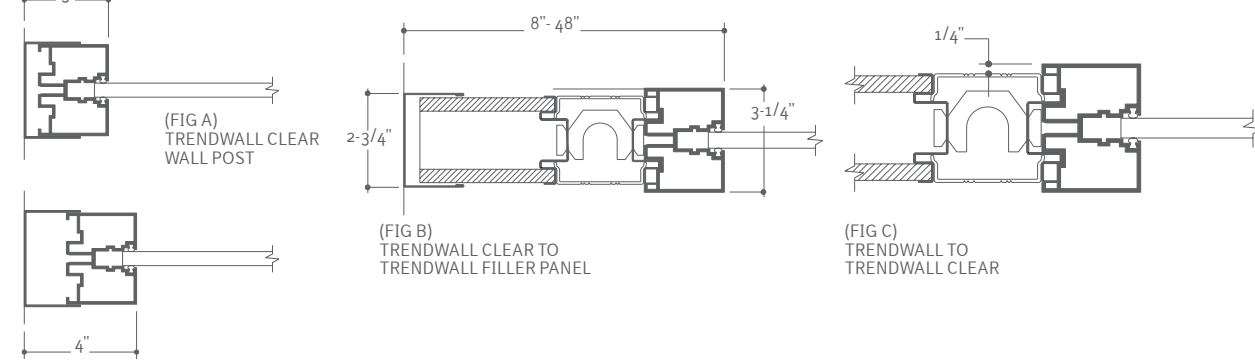

## Power and Data

TrendWall Clear has the ability to integrate power and data into the system via Vertical Posts. All vertical framing elements (except doorjamb) are designed to accept TrendWall Clear power modules at 14" and 32" above the finished floor. Power and data can be added at TrendWall Clear doorjamb with the electrical adder post. All power modules can be powered from the ceiling. For additional information on power and data planning, see the TrendWall Power and

POWER BLOCKS

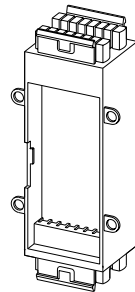

## Space Planning

Planning TrendWall Clear begins by defining the location of the partition run. TrendWall Clear is 3-1/4" thick, so using construction lines that are offset by 3-1/4" is a good place to start (Step 1). Once the desired location of the walls is determined, you can begin the office layout.

Once you determine the location of TrendWall Clear walls, the framing layout and elevations can be developed using CAP, GIZA or another office product planning software supported with Trendway symbol libraries. Development begins by locating all vertical framing elements (vertical posts and doors) and then laying in inserts. Horizontal beams can be added last, once all other framing elements have been approved.

After all doors have been placed, all other vertical framing elements should be placed, as they will dictate the glass sizes. TrendWall and TrendWall Clear can be integrated by combining Vertical Posts and TrendWall Transition Posts. Remember that TrendWall is 2-3/4" thick, so that when bringing the two systems together, there will be a 1/4" step on both sides of the system. Due to this difference in thickness, it is important to use centerline dimensioning on all installation drawings to avoid confusion. Once all doors and transition posts are located, any other posts can be placed to accommodate additional power, structural or aesthetic requirements.

Once all Vertical Posts have been located and glass inserts placed (Steps 2 and 3), you can place all horizontal beams. TrendWall Clear Upper Beams span from wall start to wall start or from wall start to sliding door jambs (as these verticals go from floor to ceiling). Lower Beams span from post to post (Step 4).

STEP 1: LOCATE OFFICE CENTERLINES

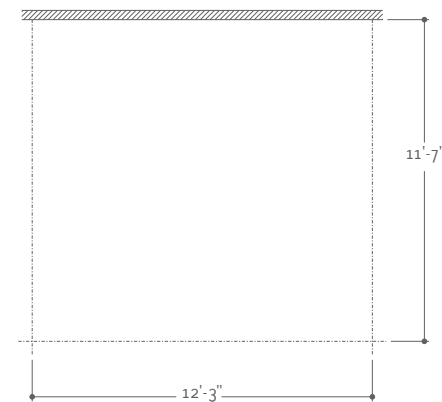

STEP 2: PLACE VERTICAL POSTS

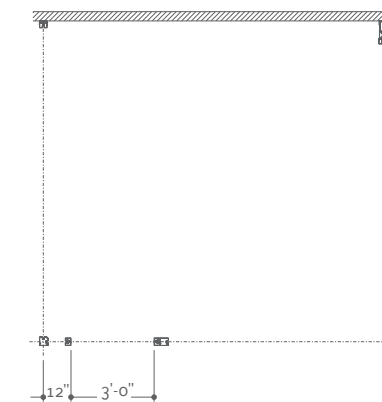

STEP 3: PLAN GLASS INSERTS

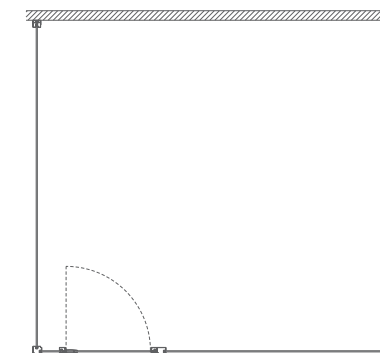

STEP 4: ADD COVERS

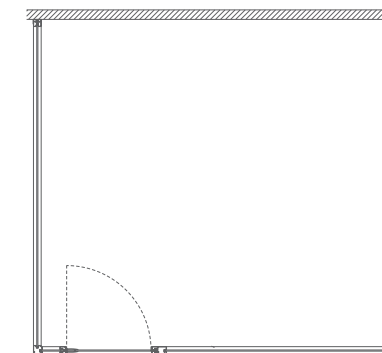

# TrendWall Clear Installation

## STEP 1: Framing Elements

### Upper Beam

- Working from your TrendWall Clear floorplan, use tape or chalk to create a layout on the ceiling.

### Lower Beam

- Drop plumb lines from the crown to the floor.
- Use tape or a chalk line to create a panel layout duplicating the layout of the Upper Beam. (Hint: Baby powder in the chalk line makes cleaning up easy.)

### Full Height Vertical Posts

*Note: All TrendWall Clear Wall starters are cut to fit from finished floor to ceiling.*

- Locate all Hardwall Transition Posts and mark their locations.
- Cut to length and install.

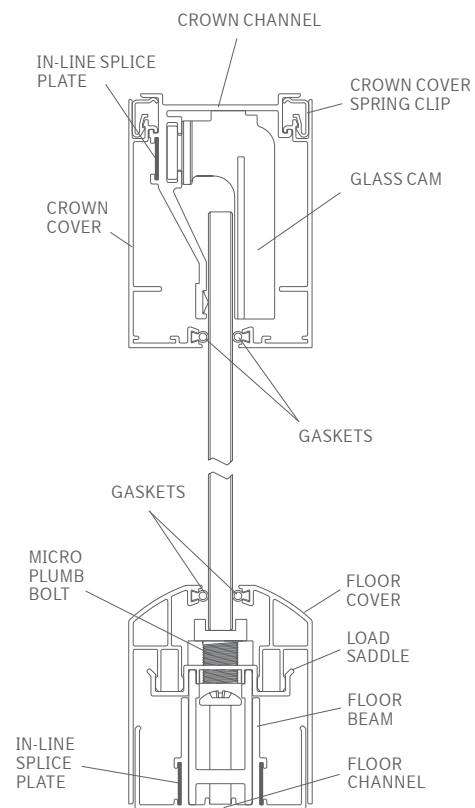

## STEP 2: Inserts

### Sub-Crown Cover Vertical Posts and Inserts

*Note: The unique glass retainment cam allows for tool-free glass installation.*

- Unless otherwise noted on the TrendWall Clear floorplan, all other Vertical Posts are installed below the Upper Beam.
- Locate all these Vertical Posts on the floor and continue to install:
  - Upper Beams continuously from Full Height Post to Full Height Post
  - Doorjamb
  - Lower Beams, in between all Vertical Posts
- Due to the semi-progressive nature of TrendWall Clear, some inserts may need to be installed prior to the balance of the Vertical Posts.
- Following the TrendWall Clear floorplan, progress from one run to another until all Vertical Posts and inserts are in place.

## STEP 3: Electrical, Doors and Covers

### Electrical

- Locate Power Blocks in the TrendWall Clear plan and install.
- Drop ceiling feeds per the plan.
- Lay in wiring harnesses to join all remaining Power Blocks.

### Doors

- Ensure the floor is level to +/- 1/4" in the door swing path, so the factory undercut door can swing free. If not, doorjamb will need to be shimmed up to allow the door to swing freely.
- Once all doorjamb are properly secured, doors can be hung in door openings.

### Covers

- Once all electrical is run and doors are hung, the covers can be cut and installed. To do this, measure the distance between posts.
- Snap covers into place. Covers are field cut to that dimension onsite, ensuring an exact fit.



*more than*  
Raise your expectations.



TrendWall Flooring Solution  
ARCHITECTURAL FLOORS



## Step Up to TrendWall Flooring Solution

Make quick work of cable management with TrendWall Flooring Solution, a low-profile access floor system that provides a practical solution for power and data throughout your interior. Due to its non-metallic construction and 2-1/2" low profile height, TrendWall Flooring Solution easily integrates in both retrofit and renovation projects. While traditional wiring systems are often cumbersome to access when moves, adds and changes are required, TrendWall Flooring Solution is completely modular, making reconfigurations much easier because power and data can be easily accessed anywhere in the room just by removing a floor access panel. If flexibility, speed and value are important, TrendWall Flooring Solution is a natural fit.

### Trendway Specified

- 1 Send us your floorplan as a CAD drawing, complete with measurements and a list of your power access needs.
- 2 We engineer your TrendWall Flooring Solution to your specifications, create a floorplan and send it to you with a quote in less than one week.
- 3 Together, we work through revisions so the floorplan blueprint meets your exact specifications.
- 4 You approve your final floorplan blueprint and place your order.
- 5 We build and ship your order, and install around your schedule, all within six weeks.

### 100% Support

Trendway Architectural Products dealers are trained professionals, so they know how to get the job done on time, on budget and always on target with your architectural plans. From planning and specifying to installation and reconfiguration, your dealer will be your consistent link to Trendway – and a constant partner throughout the planning process.

Count on your Trendway Architectural Products dealer to:

- Inspect your site.
- Take accurate measurements.
- Provide a customized financial analysis.
- Help maximize your floorplan.
- Assist with your electrical and data planning.
- Tackle the finishing touches like trim, doors, closets and components.

### Core no more.

Counting on coring? Consider TrendWall Flooring Solution. No dust, no fuss, no worries about the downtime and expense created by coring. TrendWall Flooring Solution installs over the subfloor, so it's a snap to put up and tuck things under.

## TrendWall Flooring Solution Components

### Floor Elements

The TrendWall Flooring Solution begins with Floor Elements, which consist of Floor Access Panels and Modular Base Units. Modular Base Units provide the 2" lift off the existing subfloor. The 2" support cylinders are on 6" centers to provide the greatest flexibility and support. The non-metallic Floor Access Panels are 24" x 24" (600mm x 600mm) and are attached to the Modular Base Unit with a #2 Phillips drive screw.

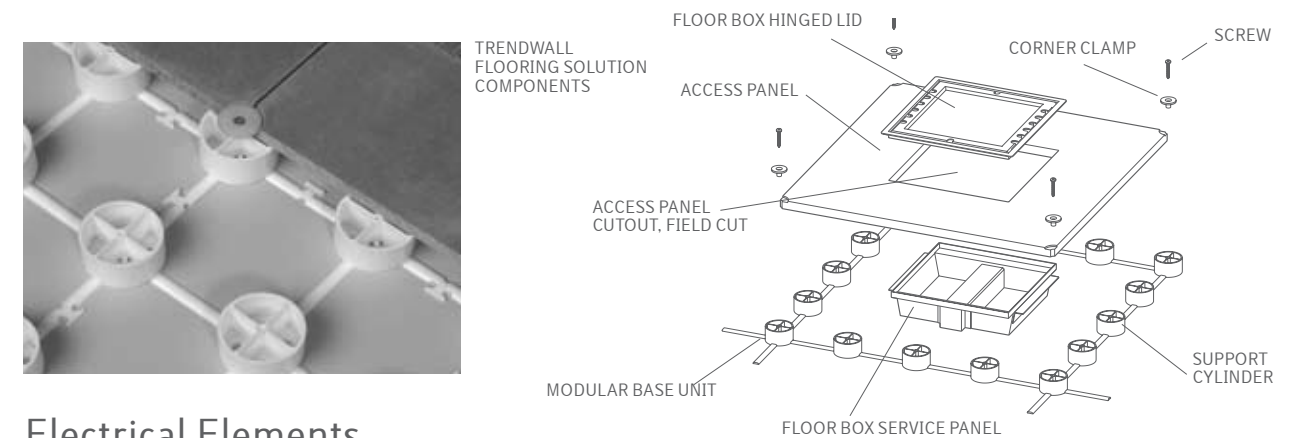

### Electrical Elements

The basic electrical components of the TrendWall Flooring Solution are Floor Boxes, wiring jumpers and distribution boxes. Floor Boxes allow user access to power and data, and can be placed virtually anywhere within the system. Floor Boxes can be specified as pre-wired (hardwired) or modular. TrendWall Flooring Solution's modular power is part of Trendway's POWERPAC® Electrical System which is an 8 wire (4 hot, 2 neutral, 2 ground), 4 circuit system (one with a dedicated neutral and ground). On the other end of the system are Distribution Boxes that are wired into building power and allow Floor Boxes to be tied into the system via pre-wired, plug and play wiring jumpers.

Because TrendWall Flooring Solution is powered by Trendway's POWERPAC Electrical System, all Trendway Architectural Products and panel systems can be easily – and modularly – tied into the access floor. Just make sure all systems are clearly noted on all requests for proposal, to ensure proper jumpers are specified.



# TrendWall Flooring Solution Installation

## STEP 1: Existing Building Subfloor Standards and Preparation

You can install TrendWall Flooring Solution over any type of subfloor – wood, concrete, flagstone, steel, vinyl, parquet, etc. – provided that the floor is hard, flat, dry, clean and level to 3/8" over 10'.

### New Construction

Concrete floor slabs should be depressed or curbed 2-1/2" in height at all shear walls, firewalls, columns and other non-access floor areas, to eliminate the need for ramps.

All permanent walls, such as perimeter and core walls, should be built and finished before beginning the access floor installation. Non-load bearing walls and architectural wall systems like TrendWall or TrendWall Clear can be built on top of the access floor, after the installation is complete. Just install them directly on TrendWall Flooring Solution.

*NOTE: In either case, check with local building officials for code compliance regarding raised floor applications on various subfloor materials and building type/use.*

## STEP 2: Laying Out TrendWall Flooring Solution

This step is facilitated by the Trendway provided shop drawing, which shows the installation start point and ideal floor panel layout. This plan however, may not show all building irregularities and must be verified prior to commencing installation. To verify the shop drawing, simply mark the start point indicated on the drawing and snap perpendicular guidelines (with one parallel to one wall) on the full length and breadth of the space. This will show how square the space is. The Trendway installation drawing will use partial floor panels that are a minimum of 6" wide around the perimeter of the space, to allow for any building wall run out. These partial insert panels are cut onsite, so a good quality portable table saw with a good carbide tipped blade is required for installation.

### Example: A 25' x 25' Install

To begin, multiply 25' x 12 (converting feet to inches): 25' x 12 = 300". Divide the result by 23.625 (the length and width of a floor panel) to get the number of whole panels and the fractional amount that will yield the insert panel dimension: 300" / 23.625 = 12.698. This number equals the exact number of whole panels (12) and the fractional amount of insert panels (.698). To find the dimension of the insert panels (and the start point), multiply the whole panel dimension (23.625) by the fractional amount (.698) and then divide that result by 2: 23.625" x .698 = 16.5" / 2 = 8.25". This calculation yields the theoretical starting point and cut size. To field verify, mark 8.25" from one wall and snap a chalk line parallel to that wall. Then snap a second line perpendicular to that line at 8.25" from the adjoining

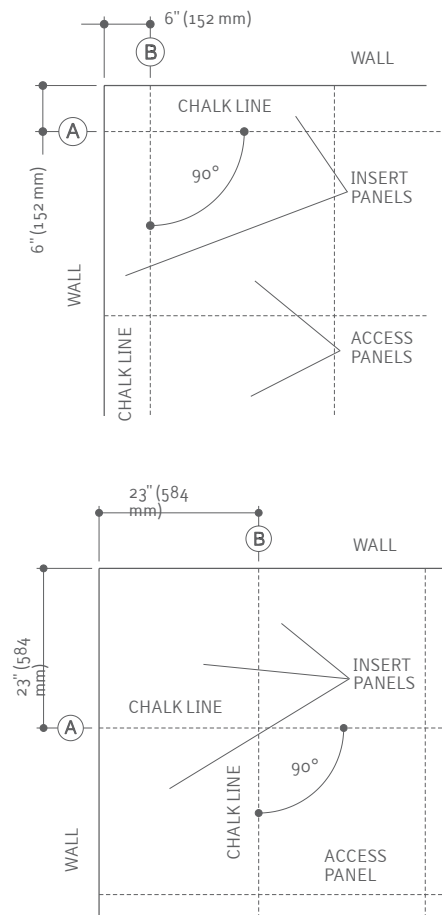

## STEP 3: Installing Modular Base Units and Access Panels

The floor should be laid progressively from the starting point along the length of the room. If the length is substantially longer than 40' (12.2m), the floor is best laid out in sections about 20 panels wide. Starting from the marked starting point and working either left-to-right or right-to-left, lay out the modular base units across the entire install, making sure they are aligned with the chalk lines. The modular base units are fastened to the subfloor with high-strength mastic construction adhesive, applied to every fourth support cylinder. The recommended adhesive for the TrendWall Flooring Solution is Michigan Adhesive Seal Bond 95 F (or the equivalent). This versatile adhesive contains no VOCs, resists flexing or racking, and bonds well to virtually any subfloor, while allowing for future de-installation and reinstallation.

Once the modular base units have been installed and the mastic has set up, the access panels can be installed. Starting with the first full panel, layout all panels, loosely screwing them in place. Place the first access panel into position by aligning two edges on the rows of support cylinders where the chalk lines (A) and (B) intersect. The panel edges should cover only half of each outside support cylinder in the rows aligned with the chalk lines. Continue laying the first row of access panels along the entire first row of modular base units. If it's necessary to adjust panels, tap the edges lightly with a rubber mallet. To allow access panels to be easily pulled up for future cabling changes, and to conform to minor subfloor level variance, the system is designed so that a space of 1/16" (1.6mm) to 1/4" (6mm) should exist between access panels. This space will vary depending on how level the subfloor is and how carefully the installation proceeds.

*Note: VERY IMPORTANT: Material allocation of the modular base is very precise. It is imperative that all support cylinders and interconnecting pads that are cut away to fit the modular base are saved for use on insert (field cut) access panels. Failure to save cutaway materials will result in a shortage and will require purchase of additional material.*

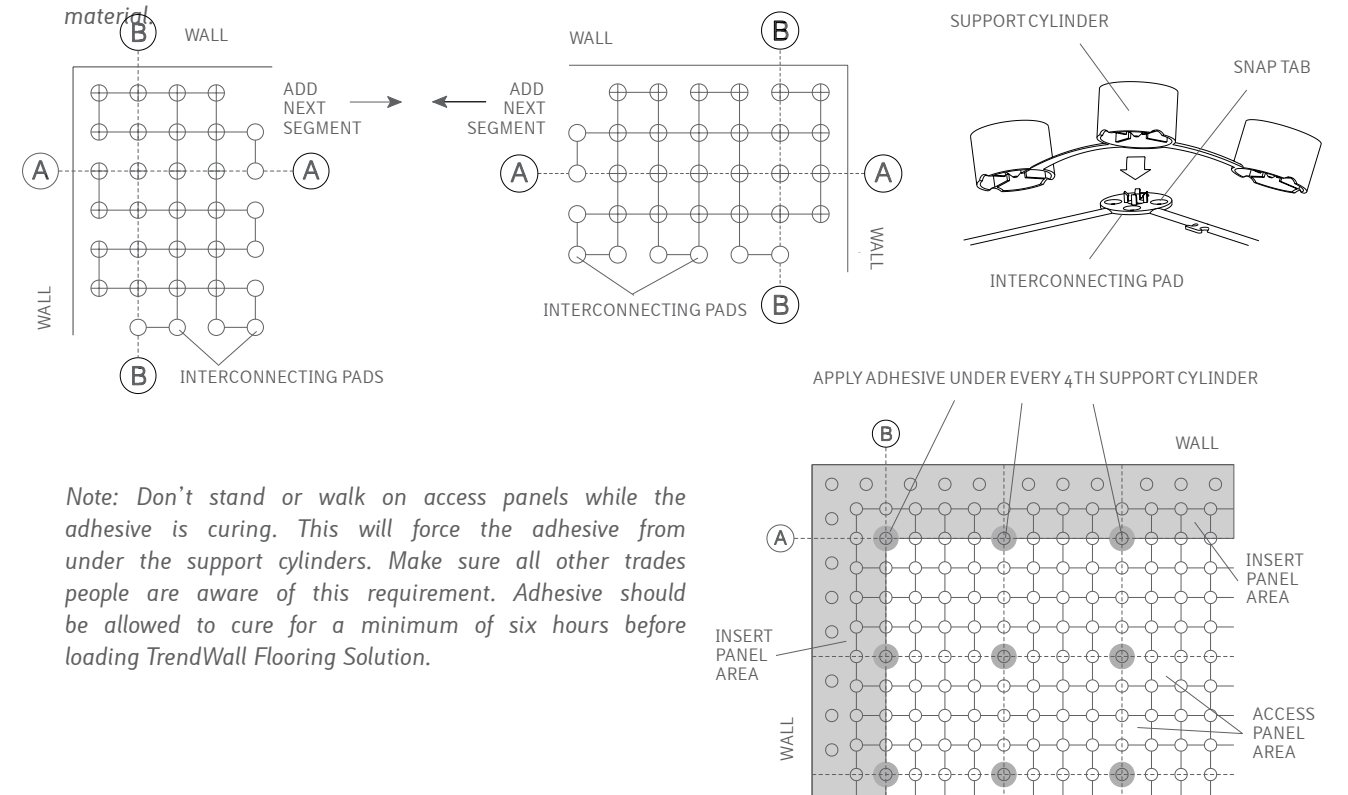

*Note: Don't stand or walk on access panels while the adhesive is curing. This will force the adhesive from under the support cylinders. Make sure all other trades people are aware of this requirement. Adhesive should be allowed to cure for a minimum of six hours before loading TrendWall Flooring Solution.*

## STEP 4: Troubleshooting

### High Spots

Overlooked a high spot on the subfloor during preparation? Depending on the size of the area affected, either grind high spots down or use a commercially available leveling compound and then feather the area to a 3/8" in 10' levelness standard.

### Low Spots

If there is an isolated low spot or dip in subfloor levelness that causes a soft spot in the floor, use extra mastic under one to four adjacent support cylinders in a quantity to off-set drops in subfloor (up to 3/8"). Be careful to not walk on or load this area for at least eight hours, to allow mastic to fully cure.

### Alignment

Check the alignment between the access panels and the support cylinders frequently. If the alignment is not square and if installation has progressed too far to adjust panels, cut the modular base segment and realign the support cylinders. Use mastic under every few support cylinders, if necessary, to secure the newly aligned section.

## STEP 5: Electrical Installation

Every TrendWall Flooring Solution project will come with a set of electrical shop drawings that indicate the routing of zone starter cables and the location of components and devices. These drawings cover the installation procedures required to complete the modular distribution system. All installations must adhere to the rules set out in national electrical codes and any local amendments.

### Zone Distribution Boxes

To install Zone Distribution Boxes, first determine the location of the Zone Boxes from the installation drawings. Then remove the four corner clamps securing the floor tile and remove the access tile. Finally, cut out and remove four support cylinders and inter-connecting straps, making room for the Zone Distribution Box, and reinstall the access panel.

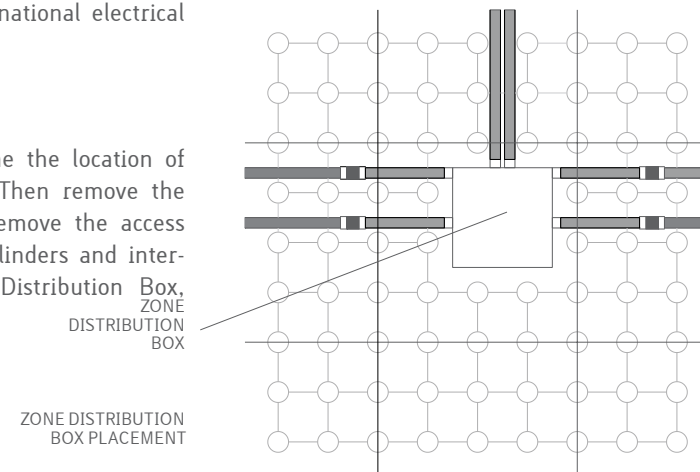

### Zone Cabling

Zone Cables are installed from the identified electrical panel, in the specified raceways, and terminated into the appropriate Zone Distribution Box.

### Floor Modules

TrendWall Flooring Solution Flush Lid Service Modules can accommodate almost any combination of wiring devices or voice/data connectors. Flush Lid Service Modules feature an open design that allows easy access for services at floor level. A low-profile hood protects all plugs and jacks from accidental damage.

*Note: You can place cutouts within access panels wherever you like, but we recommend placing cutouts off-center so you can revolve the panel 90 degrees or 180 degrees, and thereby put service in any of four locations below the floor within a single cutout.*

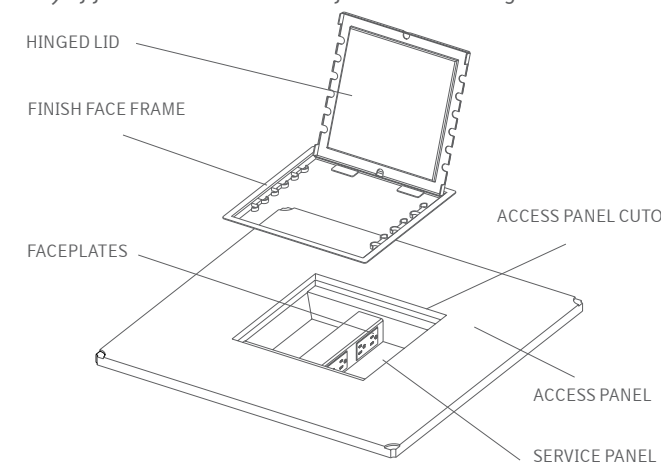

FLUSH LID SERVICE MODULE ASSEMBLY

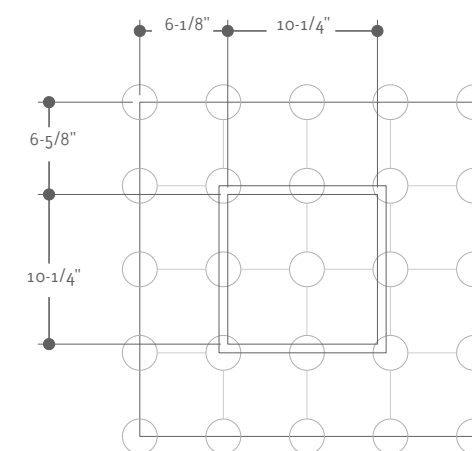

FLUSH LID SERVICE MODULE CUTOUT LOCATION

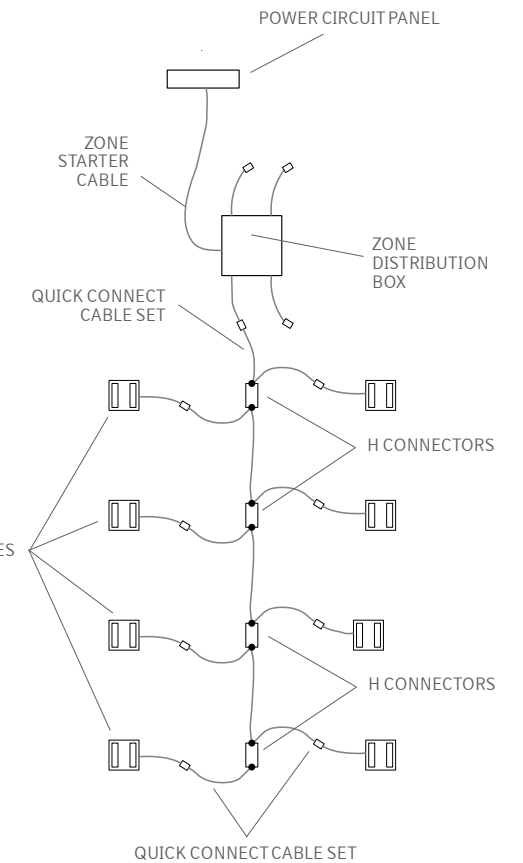
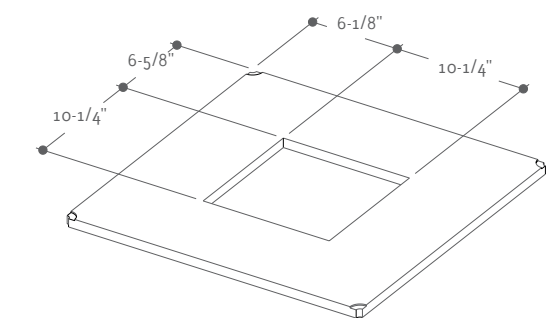



## Total workplace solutions, total customer satisfaction.

Trendway delivers not just furniture but something more: fast, flexible solutions backed by unflappable customer service and a 99.9% on-time, complete delivery record. We make furniture that works – and makes our customers happy.

Peace of mind, that's our business.

### Trendway Workplace Solutions

---

#### Systems

- Choices
- Choices Desking
- Choices Tables
- Contrada
- Contrada Raw
- Power Arch

#### Freestanding

- Choices Desking
- Intrinsic Freestanding
- Intrinsic Executive Freestanding

#### Filing and Storage

- Choices Storage
- Pack Storage

#### Seating

- Code
- Jet Stack
- Jet Task
- Live
- Live II
- Sketch
- Snap
- Stat

### Trendway Architectural Products

---

- TrendWall
- TrendWall Clear
- TrendWall Flooring Solution



Please make an appointment to visit us at:  
3401 Madison Street  
Skokie, IL 60076  
[www.appliedergonomics.com](http://www.appliedergonomics.com)

Call us  
Tel: (847) 679-5148  
Fax: (847) 933-0018

Email the President directly  
[jmeltzer@appliedergonomics.com](mailto:jmeltzer@appliedergonomics.com)