

Colour combination - Tera

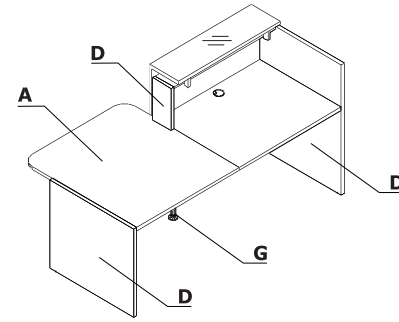
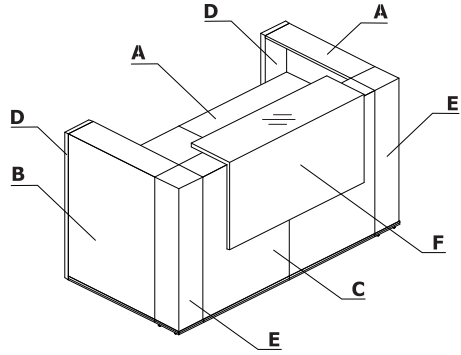

Material	Colour	All elements													
		A - Upper top, worktop	B - Body	C - Front	D - Ending elements	E - Corner unit	F - Top	G - Supporting leg							
MFC	31 - canadian oak	✓	✓	✓	✓										
	67 - white pastel	✓	✓	✓	✓										
	106 - lowland walnut	✓	✓	✓	✓										
HPL	73 - white high gloss					✓	✓								
	101 - black high gloss					✓	✓								
	155 - anthracite high gloss					✓	✓								
	Metal - M015 - white semi-mat							✓							

Technical specification

- 1 Worktop** - MFC 28 mm, ABS edge
- 2 Low side panel** - MFC 28 mm, ABS edge
- 3 Top element** - top MFC 28 mm + Glass LACOBEL 4 mm, front MFC 18 mm, coated with HPL gloss
- 4 High side panel** - MFC 28 mm, ABS edge
- 5 Front** - MFC 18 mm, ABS edge
- 6 Decorative stripe** - PVC, colour: M009 - aluminium semi-matt
- 7 Corner unit** - melamine board covered with HPL - gloss
- 8 Side panel linking low and high fronts** - MFC 28 mm, ABS edge
- 9 Frame to optional top element with lightening** - metal powder-coated, white colour
- 10 Light swich**
- 11 LED illumination** - at the full length of the reception desk, cold white color (verging on the blue shade);
- 12 Cable grommets** - Ø80 mm
- 13 Supporting leg NL41** - required for connecting the tops

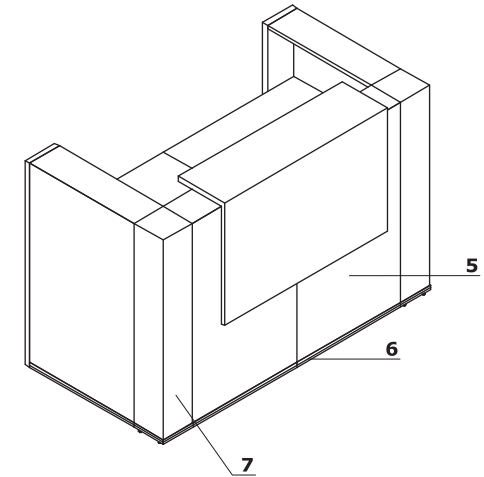
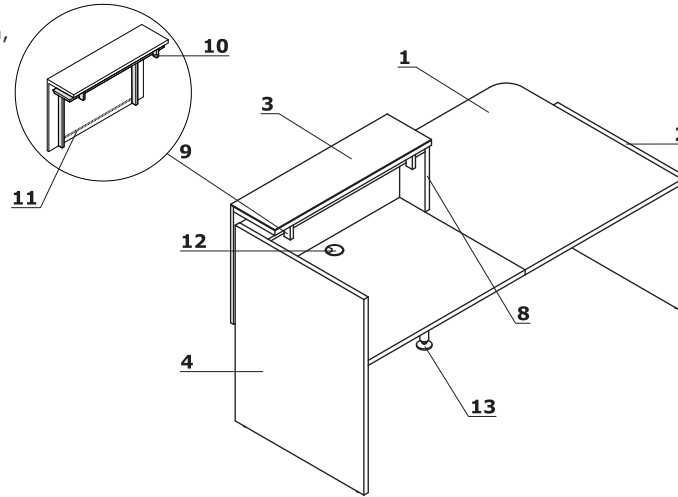

Ending elements application

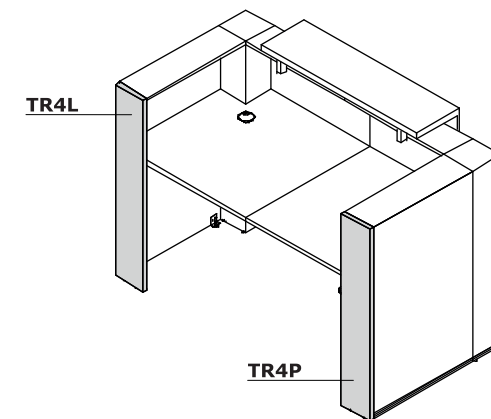
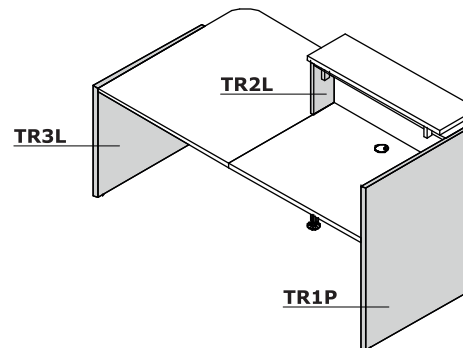
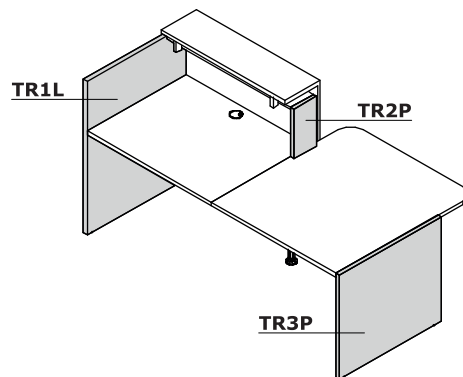

Dimensions (mm)

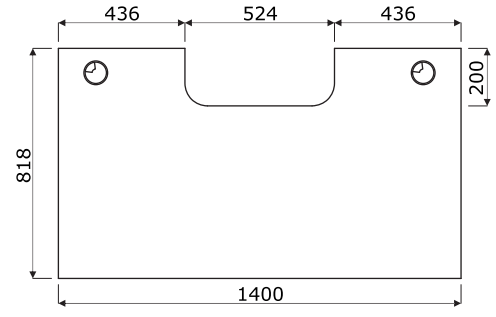
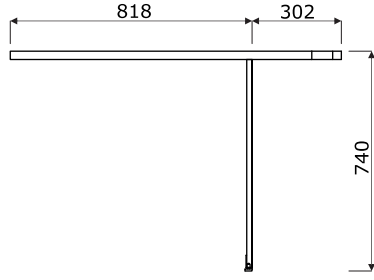
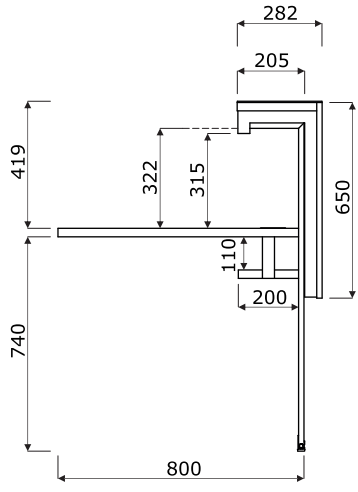

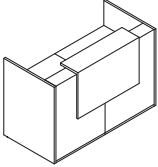
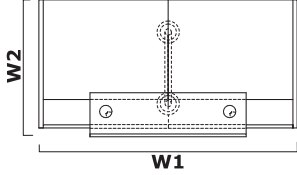
Symbol		Dimensions					kg m3 pcs	Composition elements
		W1	W2	D1	D2	H		
TRA17		1656	877	2608	838	1159	103 kg 0.425 m3 6 pcs	TR1L+2xTR08+TR99+TR1P+NL41
TRA18		2056	877	2608	838	1159	117 kg 0.449 m3 6 pcs	TR1L+2xTR10+TR99+TR1P+NL41
TRA19		2456	877	2608	838	1159	125 kg 0.473 m3 6 pcs	TR1L+2xTR12+TR99+TR1P+NL41
TRA20		2856	877	2608	838	1159	129 kg 0.498 m3 6 pcs	TR1L+2xTR14+TR99+TR1P+NL41

Extra charge						
Monitor shelf x1	Monitor shelf x 2					
X	X					
X	X					
X	X					



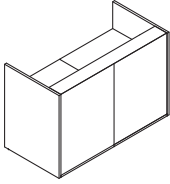
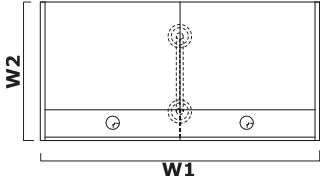

Symbol		Dimensions					kg m3 pcs	Composition elements
		W1	W2	D1	D2	H		
TRA117		1656	820	2608	838	1090	86 kg 0.242 m3 5 pcs	TR1L+2xTR08+TR1P+NL41
TRA118		2056	820	2608	838	1090	100 kg 0.266 m3 5 pcs	TR1L+2xTR10+TR1P+NL41
TRA119		2456	820	2608	838	1090	108 kg 0.29 m3 5 pcs	TR1L+2xTR12+TR1P+NL41
TRA120		2856	820	2608	838	1090	112 kg 0.314 m3 5 pcs	TR1L+2xTR14+TR1P+NL41

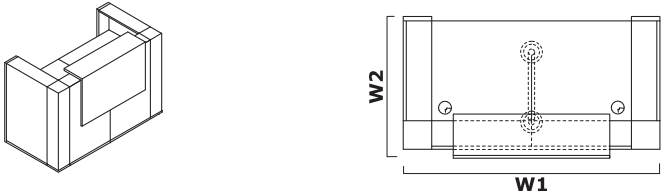
Extra charge						
Monitor shelf x1	Monitor shelf x 2					
X	X					
X	X					
X	X					

		Dimensions					kg m3 pcs	Composition elements
		W1	W2	D1	D2	H		
TRA42		1640	905	2608	838	1159	99 kg 0.46 m3 8 pcs	TR4L+2xTR90+TR4P+TR99+NL41

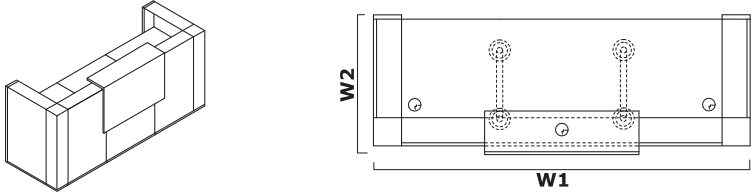
Extra charge						

		Dimensions					kg m3 pcs	Composition elements
		W1	W2	D1	D2	H		
TRA21		2440	905	2608	838	1159	126 kg 0.577 m3 10 pcs	TR4L+2xTR90+TR08+TR4P+TR99+2xNL41
TRA22		2640	905	2608	838	1159	133 kg 0.59 m3 10 pcs	TR4L+2xTR90+TR10+TR4P+TR99+2xNL41
TRA23		2840	905	2608	838	1159	137 kg 0.602 m3 10 pcs	TR4L+2xTR90+TR12+TR4P+TR99+2xNL41
TRA24		3040	905	2608	838	1159	139 kg 0.614 m3 10 pcs	TR4L+2xTR90+TR14+TR4P+TR99+2xNL41

Extra charge						
Monitor shelf x1						
	X					
	X					
	X					

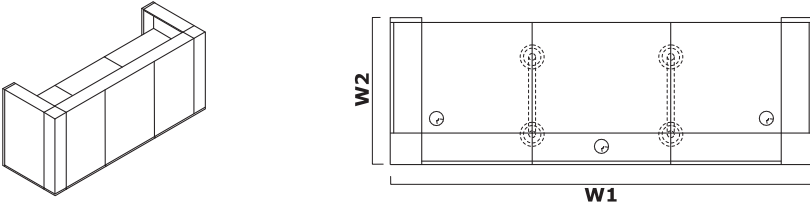

Symbol	Dimensions					kg m3 pcs	Composition elements
	W1	W2	D1	D2	H		
TRA121	2440	848	2608	838	1090	109 kg 0.394 m3 9 pcs	TR4L+2xTR90+TR08+TR4P +2xNL41
TRA122	2640	848	2608	838	1090	116 kg 0.406 m3 9 pcs	TR4L+2xTR90+TR10+TR4P +2xNL41
TRA123	2840	848	2608	838	1090	120 kg 0.418 m3 9 pcs	TR4L+2xTR90+TR12+TR4P +2xNL41
TRA124	3040	848	2608	838	1090	122 kg 0.43 m3 9 pcs	TR4L+2xTR90+TR14+TR4P +2xNL41

Extra charge						
Monitor shelf x1						
X						
X						
X						

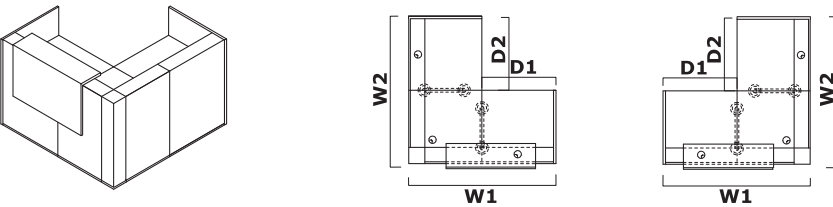

Symbol	Dimensions					kg m3 pcs	Composition elements
	W1	W2	D1	D2	H		
TRA25	1648	1705	2608	838	1159	141 kg 0.586 m3 9 pcs	TR1L+TR08+TR90+TR08+TR1P +TR99+2xNL41
TRA26	1848	1705	2608	838	1159	148 kg 0.598 m3 9 pcs	TR1L+TR08+TR90+TR10+TR1P +TR99+2xNL41
TRA27	2048	1705	2608	838	1159	152 kg 0.611 m3 9 pcs	TR1L+TR08+TR90+TR12+TR1P +TR99+2xNL41
TRA28	2248	1705	2608	838	1159	154 kg 0.623 m3 9 pcs	TR1L+TR08+TR90+TR14+TR1P +TR99+2xNL41

Extra charge						
Monitor shelf x1						
X						
X						
X						

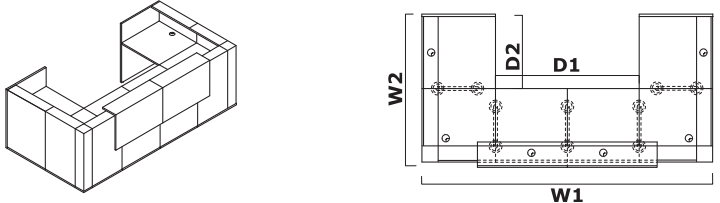

Symbol		Dimensions					kg m3 pcs	Composition elements
		W1	W2	D1	D2	H		
TRA29		3240	1705	2608	838	1159	250 kg 1.166 m3 17 pcs	TR1L+2xTR08+2xTR90+2xTR08 +TR1P+2xTR99+5xNL41
TRA30		3640	1705	2608	838	1159	264 kg 1.19 m3 17 pcs	TR1L+2xTR08+2xTR90+2xTR10+TR1P+2xTR99+5xNL41
TRA31		4040	1705	2608	838	1159	272 kg 1.214 m3 17 pcs	TR1L+2xTR08+2xTR90+2xTR12+TR1P+2xTR99+5xNL41
TRA32		4440	1705	2608	838	1159	276 kg 1.239 m3 17 pcs	TR1L+2xTR08+2xTR90+2xTR14 +TR1P+2xTR99+5xNL41

Extra charge					
Monitor shelf x1	Monitor shelf x 2				
X	X				
X	X				
X	X				

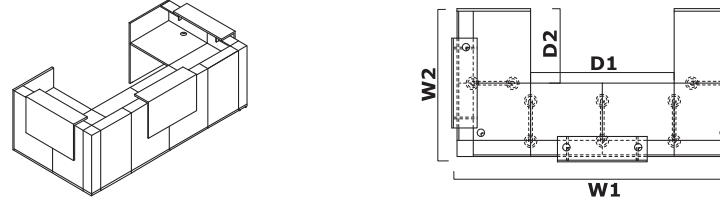

Symbol		Dimensions					kg m3 pcs	Composition elements
		W1	W2	D1	D2	H		
TRA129		3354	1705	2608	838	1159	267 kg 1.349 m3 18 pcs	TR1L+2xTR08+2xTR90+2xTR08 +TR1P+3xTR99+5xNL41
TRA130		3754	1705	2608	838	1159	281 kg 1.374 m3 18 pcs	TR1L+2xTR08+2xTR90+2xTR10 +TR1P+3xTR99+5xNL41
TRA131		4154	1705	2608	838	1159	289 kg 1.398 m3 18 pcs	TR1L+2xTR08+2xTR90+2xTR12 +TR1P+3xTR99+5xNL41
TRA132		4554	1705	2608	838	1159	293 kg 1.422 m3 18 pcs	TR1L+2xTR08+2xTR90+2xTR14 +TR1P+3xTR99+5xNL41

Extra charge					
Monitor shelf x1	Monitor shelf x 2				
X	X				
X	X				
X	X				

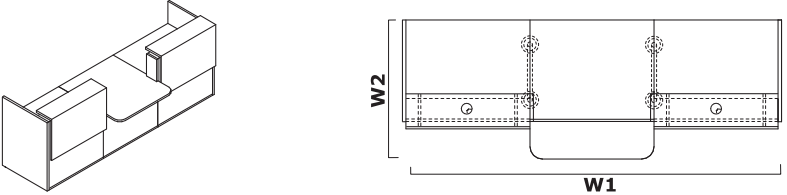

Symbol		Dimensions					kg m3 pcs	Composition elements
		W1	W2	D1	D2	H		
TRA33		3056	1120	2608	838	1159	169 kg 0.793 m3 11 pcs	TR1L+TR10+TR2P+TR11+TR2L +TR10+TR1P+2xTR99+2xNL41
TRA34		3456	1120	2608	838	1159	177 kg 0.817 m3 11 pcs	TR1L+TR12+TR2P+TR11+TR2L +TR12+TR1P+2xTR99+2xNL41
TRA35		3856	1120	2608	838	1159	181 kg 0.841 m3 11 pcs	TR1L+TR14+TR2P+TR11+TR2L +TR14+TR1P+2xTR99+2xNL41

Extra charge						
Monitor shelf x1	Monitor shelf x 2					
X	X					
X	X					
X	X					

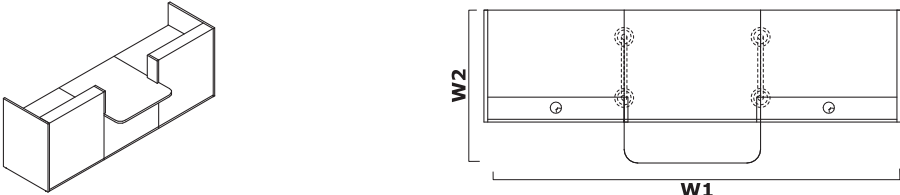

Symbol		Dimensions					kg m3 pcs	Composition elements
		W1	W2	D1	D2	H		
TRA133		3056	1120	2608	838	1090	135 kg 0.426 m3 9 pcs	TR12+TR10+TR2P+TR11+TR2L +TR10+TR1P+2xNL41
TRA134		3456	1120	2608	838	1090	143 kg 0.451 m3 9 pcs	TR12+TR12+TR2P+TR11+TR2L +TR12+TR1P+2xNL41
TRA135		3856	1120	2608	838	1090	147 kg 0.475 m3 9 pcs	TR12+TR14+TR2P+TR11+TR2L +TR14+TR1P+2xNL41

Extra charge						
Monitor shelf x1	Monitor shelf x 2					
X	X					
X	X					
X	X					

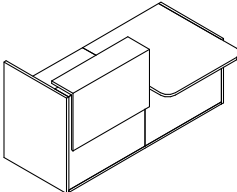

A

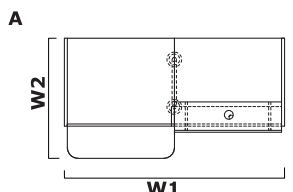

B

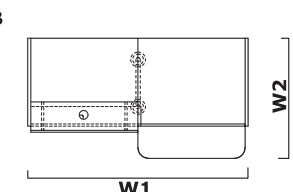

Symbol			Dimensions					kg m3 pcs	Composition elements
A	B		W1	W2	D1	D2	H		
TRA36L	TRA36P		2056	1120	2608	838	1159	111.5 kg 0.467 m3 7 pcs	A - TR1L+TR10+TR2P+TR11+TR3P +TR99+NL41 B - TR3L+TR11+TR2L+TR10+TR1P +TR99+NL41
TRA37L	TRA37P		2256	1120	2608	838	1159	115.5 kg 0.479 m3 7 pcs	A - TR1L+TR12+TR2P+TR11+TR3P +TR99+NL41 B - TR3L+TR11+TR2L+TR12+TR1P +TR99+NL41
TRA38L	TRA38P		2456	1120	2608	838	1159	158.5 kg 0.587 m3 9 pcs	A - TR1L+TR14+TR2P+TR11+TR3P +TR99+NL41 B - TR3L+TR11+TR2L+TR14+TR1P +TR99+NL41

Extra charge						
Monitor shelf x1						
X						
X						
X						

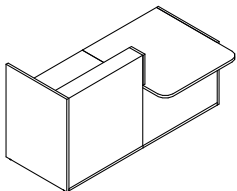

A

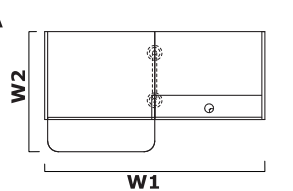

B

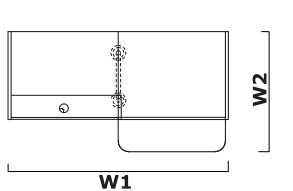

Symbol			Dimensions					kg m3 pcs	Composition elements
A	B		W1	W2	D1	D2	H		
TRA136L	TRA136P		2056	1120	2608	838	1090	94.5 kg 0.283 m3 6 pcs	A - TR1L+TR10+TR2P+TR11+TR3P +NL41 B - TR3L+TR11+TR2L+TR10+TR1P +NL41
TRA137L	TRA137P		2256	1120	2608	838	1090	98.5 kg 0.295 m3 6 pcs	A - TR1L+TR12+TR2P+TR11+TR3P +NL41 B - TR3L+TR11+TR2L+TR12+TR1P +NL41
TRA138L	TRA138P		2456	1120	2608	838	1090	100.5 kg 0.308 m3 6 pcs	A - TR1L+TR14+TR2P+TR11+TR3P +NL41 B - TR3L+TR11+TR2L+TR14+TR1P +NL41

Extra charge						
Monitor shelf x1						
X						
X						
X						

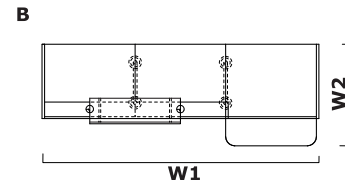
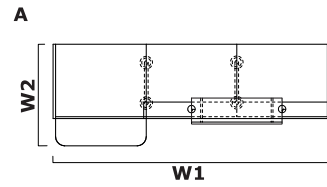
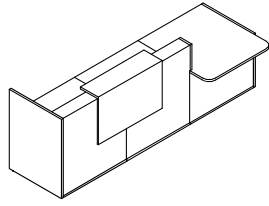

Symbol		Dimensions	kg	m ³	pcs	Composition elements		
A	B						W1	W2
TRA39L	TRA39P	3056	1120	2608	838	1159	145.5 kg 0.596 m ³ 9 pcs	A - TR1L+2xTR10+TR2P+TR11+TR3P+TR99+2xNL41 B - TR3L+TR11+TR2L+2xTR10+TR1P+TR99+2xNL41
TRA40L	TRA40P	3456	1120	2608	838	1159	153.5 kg 0.62 m ³ 9 pcs	A - TR1L+2xTR12+TR2P+TR11+TR3P+TR99+2xNL41 B - TR3L+TR11+TR2L+2xTR12+TR1P+TR99+2xNL41
TRA41L	TRA41P	3856	1120	2608	838	1159	157.5 kg 0.645 m ³ 9 pcs	A - TR1L+2xTR14+TR2P+TR11+TR3P+TR99+2xNL41 B - TR3L+TR11+TR2L+2xTR14+TR1P+TR99+2xNL41

Extra charge						
Monitor shelf x1	Monitor shelf x 2					
X	X					
X	X					
X	X					

