



Workrite
ergonomics®

ESSENTIA
benching system

ESSENTIA BENCHING SYSTEM

The need to create collaborative work environments that optimize every square foot of space has changed the landscape of today's office. Unfortunately, these needs are often met at the expense of worker productivity and with products that restrict future flexibility.

Recognizing these challenges, we set out to develop a solution that would address these issues while enabling the creation of collaborative, open space environments.

The answer was simple.

Based on our most popular foot design, we created a patented pending dual platform foot and connector system that can easily convert individual workstations to a benching system with all of the essential components located just below the work surface, resulting in the most flexible and cost effective benching system available today.

No more bulky frames, complex power distribution systems, or workcenters so large they are impossible to move.



Quick Reference Chart — Pre-configured Essentia Benching Systems

The following quick reference chart shows required and optional components for pre-configured Essentia 2, 4, 6, 8 and 10 Station Benching System Kits. These kits are designed to make ordering simple, optimize palletization, and reduce the amount of waste on site.

	2 Station	4 Station	6 Station	8 Station	10 Station
WORKSURFACE Benching - 29" Deep Only T4629-XX-B3-XXXXXXX-XXX, T5829-XX-B3-XXXXXXX-XXX or T7029-XX-B3-XXXXXXX-XXX (options include width, grommet type, laminate and edge band colors)	Order separately/ Required 2 Each	Order separately/ Required 4 Each	Order separately/ Required 6 Each	Order separately/ Required 8 Each	Order separately/ Required 10 Each
GROMMET ONLY KIT ACC-PWR-REMNT-X or ACC-PWR-INMNT-X	Order separately/ Required 2 Each	Order separately/ Required 4 Each	Order separately/ Required 6 Each	Order separately/ Required 8 Each	Order separately/ Required 10 Each
LAMINATE MODESTY PANEL ACC-MODPNL-41-B3-XXXXXXX-XXX ACC-MODPNL-53-B3-XXXXXXX-XXX ACC-MODPNL-65-B3-XXXXXXX-XXX	Optional 2 Each	Optional 4 Each	Optional 6 Each	Optional 8 Each	Optional 10 Each
LAMINATE MODESTY PANEL MOUNT KIT, SILVER ACC-MODMNTKIT-S	Not included/ Only required when ordering laminate modesty panel without cable trough				
ESSENTIA FRAME SETS, SILVER ES3E30-48-S or ES3E54-72-S	Included/ Required 2 Each	Included/ Required 4 Each	Included/ Required 6 Each	Included/ Required 8 Each	Included/ Required 10 Each
ESSENTIA FLAT FOOT KIT, DUAL STATIONS, SILVER ES-BFK48-S	Included/ Required 1 Kit	Included/ Required 2 Kits	Included/ Required 3 Kits	Included/ Required 4 Kits	Included/ Required 5 Kits
BENCH FOOT CONNECTOR KIT, DUAL STATIONS, SILVER ES-BF-CONKIT-S	N/A	Included/ Required 1 Kit	Included/ Required 2 Kits	Included/ Required 3 Kits	Included/ Required 4 Kits
ESSENTIA PROGRAMMABLE SWITCH ES-P-SWITCH	Included/ Required 2 Each	Included/ Required 4 Each	Included/ Required 6 Each	Included/ Required 8 Each	Included/ Required 10 Each
POWER MODULE, CIRCUIT 1, BLACK ACC-PMC1-4P2U-B	Included/ Required 2 Each	Included/ Required 4 Each	Included/ Required 3 Each	Included/ Required 4 Each	Included/ Required 5 Each
POWER MODULE, CIRCUIT 2, BLACK ACC-PMC2-4P2U-B	N/A	N/A	Included/ Required 3 Each	Included/ Required 4 Each	Included/ Required 5 Each

	2 Station	4 Station	6 Station	8 Station	10 Station
POWER JUMPER BLOCK, BLACK ACC-PWR-JBLOCK-B	Included/ Required 1 Each	Included/ Required 3 Each	Included/ Required 5 Each	Included/ Required 7 Each	Included/ Required 9 Each
POWER IN FEED CABLE ACC-PWR-IN-HDWR-B	Included/ Required 1 Each	Included/ Required 1 Each	Included/ Required 1 Each	Included/ Required 1 Each	Included/ Required 1 Each
POWER CROSS CABLE ACC-PWR-CCBL-24 ACC-PWR-CCBL-36 or ACC-PWR-CCBL-48	Included/ Required 1 Each	Included/ Required 3 Each	Included/ Required 5 Each	Included/ Required 7 Each	Included/ Required 9 Each
JUMPER CABLE, SIDE TO SIDE, 50" ACC-PWR-JSSCBL-50-B	N/A	Included/ Required 2 Each	Included/ Required 4 Each	Included/ Required 6 Each	Included/ Required 8 Each
JUMPER CABLE BACK TO BACK, 54" ACC-PWR-JBBCBL-54-B	Included/ Required 1 Each	Included/ Required 1 Each	Included/ Required 1 Each	Included/ Required 1 Each	Included/ Required 1 Each
CABLE TROUGH WITH END PLATES ACC-CBLTRKIT-41-S ACC-CBLTRKIT-53-S ACC-CBLTRKIT-65-S	Included 2 Each	Included 4 Each	Included 6 Each	Included 8 Each	Included 10 Each
CABLE MANAGER CHAIN, SILVER POWER ENTRY, SIDE TO SIDE, OR BACK TO BACK ACC-PWR-CBLCHAIN-S	Optional 2 Each	Optional 4 Each	Optional 6 Each	Optional 8 Each	Optional 10 Each
CABLE CHAIN TROUGH MOUNT KIT, SILVER POWER ENTRY, SIDE TO SIDE, OR BACK TO BACK ACC-PWR-CHTRMT-S	Optional 2 Kits	Optional 4 Kits	Optional 6 Kits	Optional 8 Kits	Optional 10 Kits
CABLE CHAIN DESK/FLOOR MOUNT KIT, SILVER POWER ENTRY FROM FLOOR ACC-PWR-CHFLRMT-S	Optional 1 Kit	Optional 1 Kit	Optional 1 Kit	Optional 1 Kit	Optional 1 Kit
TOOL BARS 980-46-S, 980-58-S, 980-70-S	Optional 2 Each	Optional 4 Each	Optional 6 Each	Optional 8 Each	Optional 10 Each
PRIVACY PANELS 981-46-S, 981-58-S, 981-70-S	Optional 2 Each	Optional 4 Each	Optional 6 Each	Optional 8 Each	Optional 10 Each
TRANQUILITY PANELS TRQ-PET-28X26-XXX, TRQ-PET-455X26-XXX, TRQ-PET-575X26-XXX, TRQ-PET-695X26-XXX, TRQ-WOOL-28X26-XXX, TRQ-WOOL-455X26-XXX, TRQ-WOOL-575X26-XXX, TRQ-WOOL-695X26-XXX	Optional 2 Rear + 4 Side Panels	Optional 4 Rear + 8 Side Panels	Optional 6 Rear + 12 Side Panels	Optional 8 Rear + 16 Side Panels	Optional 10 Rear + 20 Side Panels
TRANQUILITY MOUNTING KITS TRQ-MNT-DESK3PNL-BA	Optional 2 Each	Optional 4 Each	Optional 6 Each	Optional 8 Each	Optional 10 Each

Pre-configured Essentia Benching Systems

To simplify the planning and ordering process, we developed these pre-configured systems, including all of the necessary components **with the exception of worksurfaces and grommet kits which require color selections and must be ordered separately.**

All pre-configured systems feature our most popular options including programmable switches and silver frame sets. Additional color selections and features are available through the a la carte program.

2 Station Configuration

Actual Top Size (W x D)	Model #	Footprint Area *	List
46" x 29"	ES3E48-B02-WP-S	46" x 62"	\$4,470
58" x 29"	ES3E60-B02-WP-S	58" x 62"	\$4,576
70" x 29"	ES3E72-B02-WP-S	70" x 62"	\$4,612

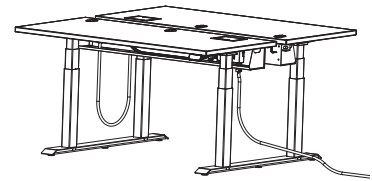

(Shown with worksurfaces, sold separately)

4 Station Configuration

Actual Top Size (W x D)	Model #	Footprint Area *	List
46" x 29"	ES3E48-B04-WP-S	96" x 62"	\$9,095
58" x 29"	ES3E60-B04-WP-S	120" x 62"	\$9,307
70" x 29"	ES3E72-B04-WP-S	144" x 62"	\$9,379

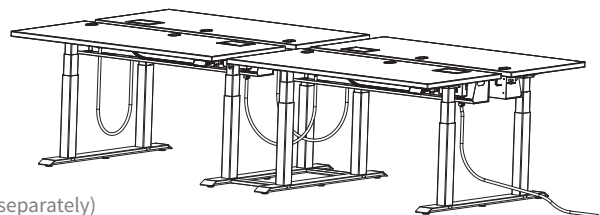

(Shown with worksurfaces, sold separately)

* Not including seating area. We recommend allowing 42" additional space in front of each workcenter to accommodate seating.

6 Station Configuration

Actual Top Size (W x D)	Model #	Footprint Area *	List
46" x 29"	ES3E48-B06-WP-S	146" x 62"	\$13,855
58" x 29"	ES3E60-B06-WP-S	182" x 62"	\$14,173
70" x 29"	ES3E72-B06-WP-S	218" x 62"	\$14,281

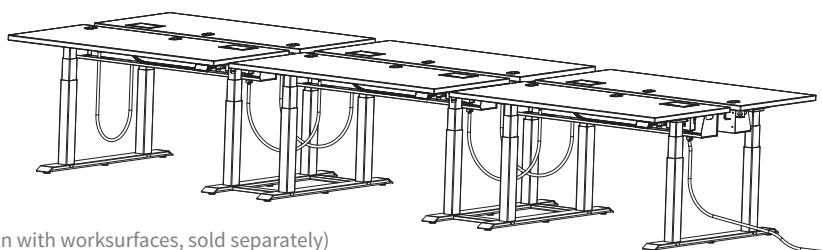

(Shown with worksurfaces, sold separately)

8 Station Configuration

Actual Top Size (W x D)	Model #	Footprint Area *	List
46" x 29"	ES3E48-B08-WP-S	196" x 62"	\$18,615
58" x 29"	ES3E60-B08-WP-S	244" x 62"	\$19,039
70" x 29"	ES3E72-B08-WP-S	292" x 62"	\$19,193

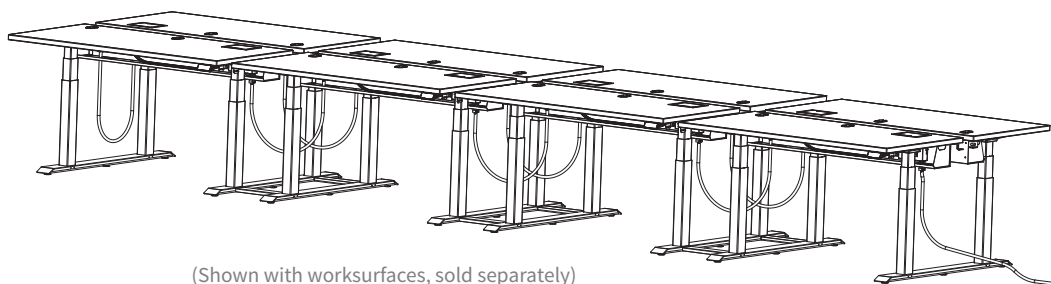

(Shown with worksurfaces, sold separately)

10 Station Configuration

Actual Top Size (W x D)	Model #	Footprint Area *	List
46" x 29"	ES3E48-B10-WP-S	246" x 62"	\$23,375
58" x 29"	ES3E60-B10-WP-S	306" x 62"	\$23,905
70" x 29"	ES3E72-B10-WP-S	366" x 62"	\$24,085

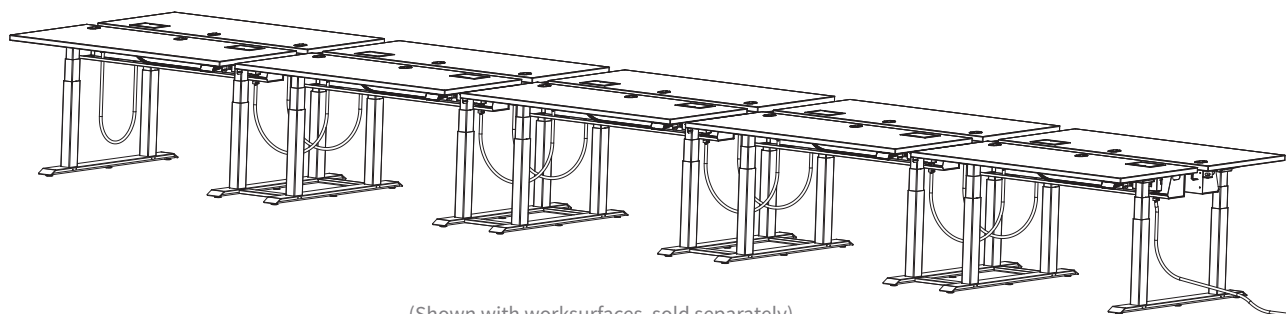

(Shown with worksurfaces, sold separately)

* Not including seating area. We recommend allowing 42" additional space in front of each workcenter to accommodate seating.

How to Build Pre-configured Systems

Select workspace type, width, laminate and edge band color.

Select power grommet kit type and color.

Select pre-configured number of stations with corresponding frame width (example shown is 6 station system.)

Select optional Above and Below Desk Accessories.

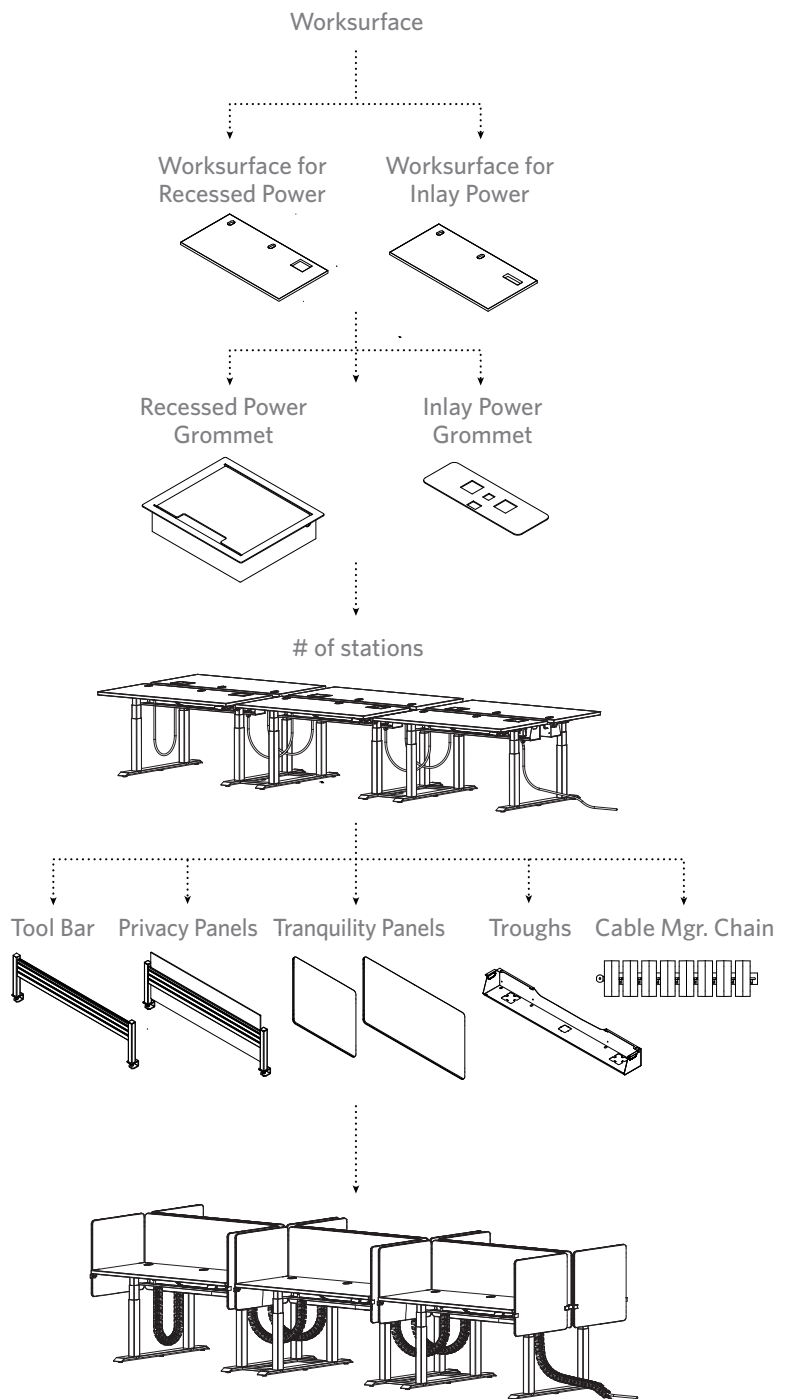

How to Build A la Carte Systems

Select worksurface type, width, laminate and edge band color. Then select corresponding grommet kit.

Add power distribution modules and select power in-feed and distribution cables (not applicable with no power worksurface).

Select frame set size, finish, and quantity required for number of workstations desired.

Select switch.

Select foot style.

- Back-to-Back – Dual
- Side-to-Side or Stand Alone/Single Workcenter

Select Foot Connector Kit.

Select Above and Below Desk Accessories.

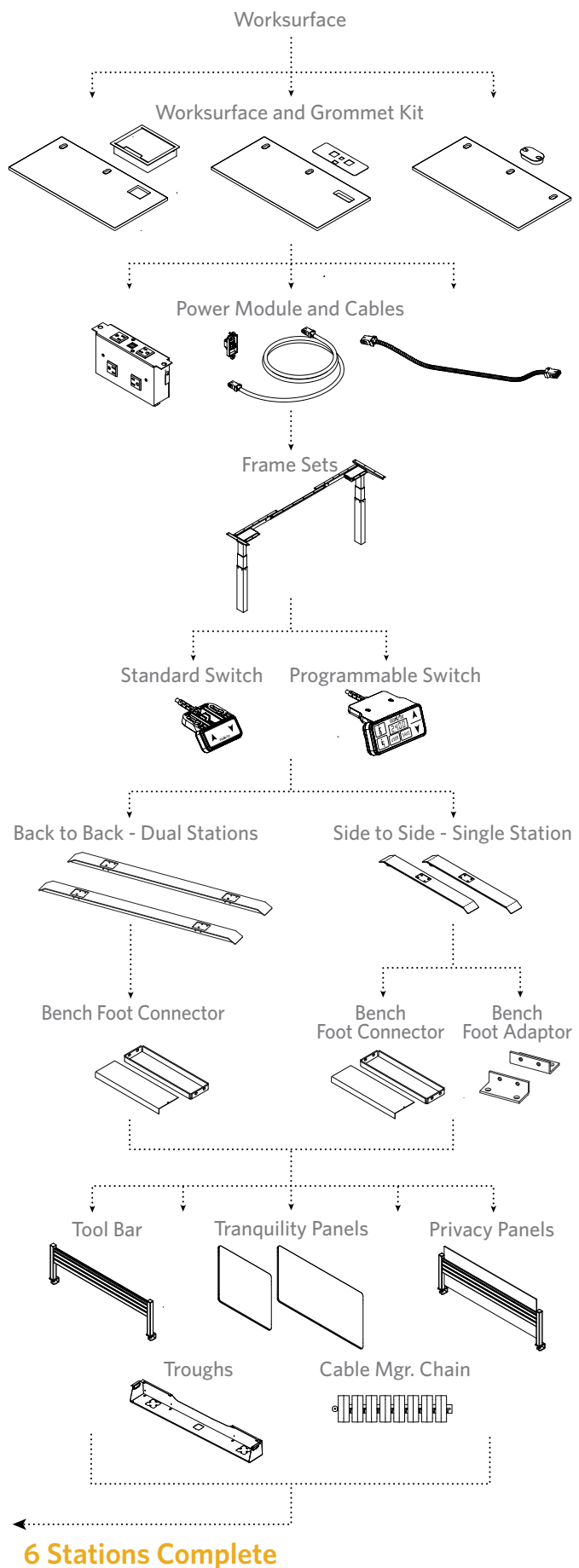
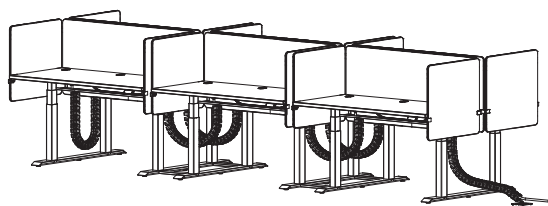

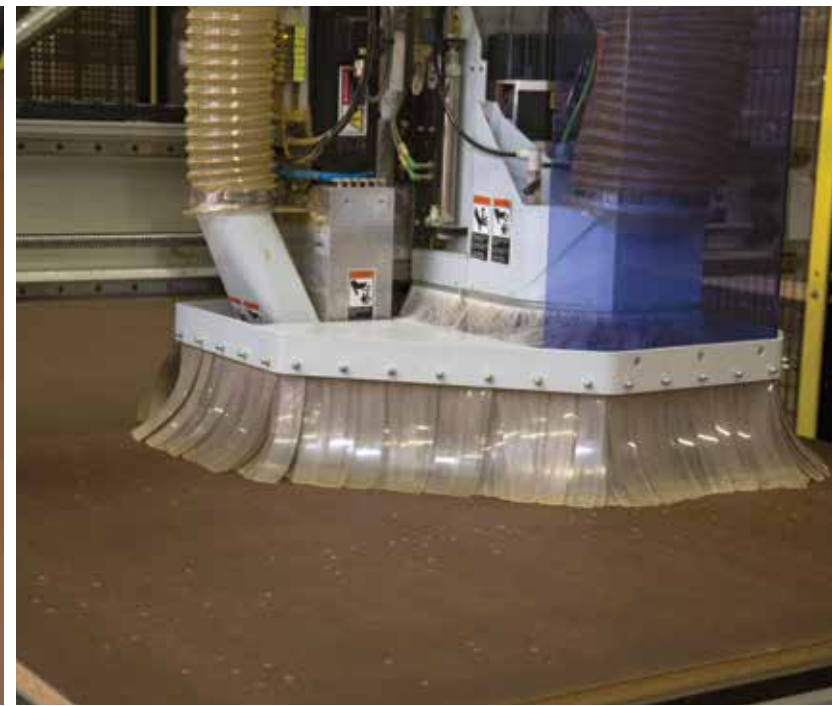
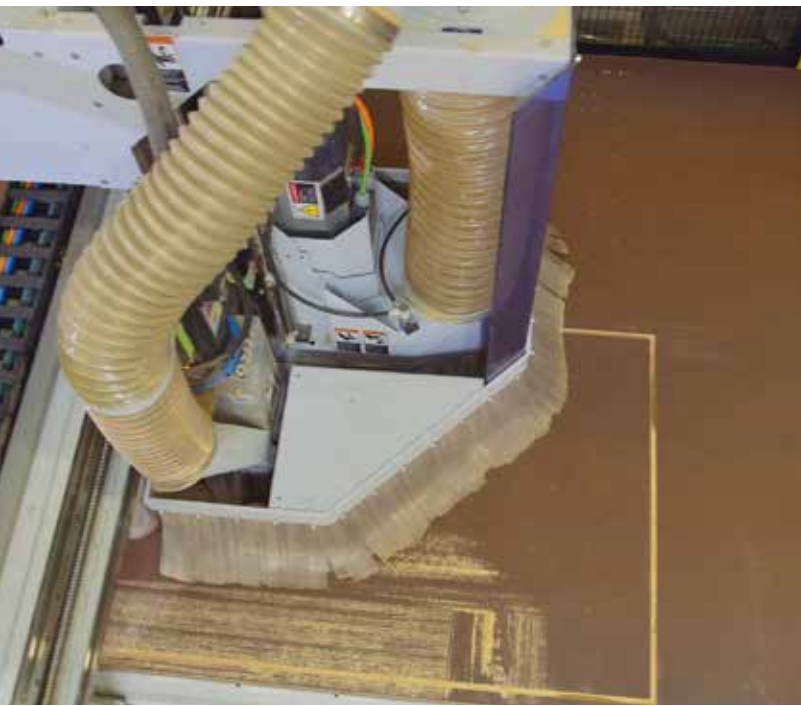

Workrite's laminated worksurfaces and rigid modesty panels feature a wide variety of popular Wilsonart® high pressure decorative laminates and coordinated edgeband. The worksurface core is constructed from 1.125" thick, 45 pound density industrial grade particleboard and is backed with high quality phenolic to ensure balanced panel construction and prevent warping over the life of the product.

Worksurfaces are pre-drilled with mounting locations for all frame sets and accessories, saving time and money during installation and creating perfectly aligned workstations every time.

Standard lead time for our laminated worksurfaces is 10 business days for quantities of 10 or less. Lead times for larger product orders will be provided upon receipt of the order.

All Workrite laminated products carry a 5 year warranty. Refer to Workrite's Standard Terms & Conditions for warranty details.

SELECTING YOUR WORKSURFACE



Select a worksurface laminate & edgeband

Workrite's standard laminated worksurface program features 19 popular Wilsonart® laminates with coordinating 3 mm edgeband options. For larger, more accurate swatches of available laminates, please refer to the Materials & Finishes tab of the Workrite binder.

Laminates



Edgeband



A guide to the benching worksurface model

Worksurface part numbers consist of :

Size
Power Type
Edge
Laminate color
Edgeband color

T3423-RP-B3-0705460-152

The example shown is for a 34" x 23" top with recessed power & block edge Wild Cherry laminate with Rainier Cherry 3 mm edgeband.

Worksurfaces for Recessed Power

Bench Station Worksurfaces for Recessed Power Kit

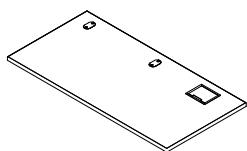

W	D	Model # - (X's represent color choice)	Weight	List
46	29	T4629-RP-B3-XXXXXXX-XXX	43	\$410
58	29	T5829-RP-B3-XXXXXXX-XXX	55	\$450
70	29	T7029-RP-B3-XXXXXXX-XXX	66	\$495

Recessed Power Grommet Kit

Required - Use with Top Listed Above

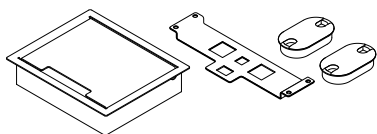

Model #			Weight	List
Gray	Black	White		
ACC-PWR-REMNT-G	ACC-PWR-REMNT-B	ACC-PWR-REMNT-W	2	\$256

• Available in 3 colors to compliment laminate selection

Worksurfaces for Inlay Power

Bench Station Worksurfaces for Inlay Power Kit

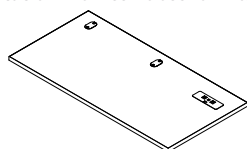

W	D	Model # - (X's represent color choice)	Weight	List
46	29	T4629-IP-B3-XXXXXXX-XXX	43	\$410
58	29	T5829-IP-B3-XXXXXXX-XXX	55	\$450
70	29	T7029-IP-B3-XXXXXXX-XXX	66	\$495

Inlay Power Grommet Kit

Required - Use with Top Listed Above

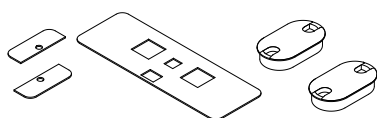

Model #			Weight	List
Gray	Black	White		
ACC-PWR-INMNT-G	ACC-PWR-INMNT-B	ACC-PWR-INMNT-W	2	\$115

• Available in 3 colors to compliment laminate selection

Worksurfaces for No Power

Bench Station Tops with No Power Grommet Kit

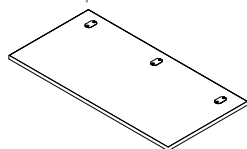

W	D	Model # - (X's represent color choice)	Weight	List
46	29	T4629-NP-B3-XXXXXXX-XXX	43	\$410
58	29	T5829-NP-B3-XXXXXXX-XXX	55	\$450
70	29	T7029-NP-B3-XXXXXXX-XXX	66	\$495

Standard Grommet Kit

Required - Use with Top Listed Above



Model #			Weight	List
Gray	Black	White		
ACC-GROM3PK-G	ACC-GROM3PK-B	ACC-GROM3PK-W	1	\$26

• Available in 3 colors to compliment laminate selection

Laminate Modesty Panel

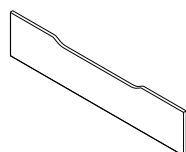

- Matching Table Sizes 46, 58, 70
- 11.75" below work surface modesty panel
- 1.25" H cable management cutout
- Match your work surface laminate
- Lightweight, 0.75" thick panel with 3mm edge band

Matching Table Size	Model # - (X's represent color choice)	Weight	List
46"	ACC-MODPNL-41-B3-XXXXXXX-XXX	10	\$159
58"	ACC-MODPNL-53-B3-XXXXXXX-XXX	11	\$234
70"	ACC-MODPNL-65-B3-XXXXXXX-XXX	12	\$241

Laminate Modesty Panel Mounting Kit

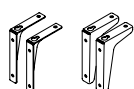

- Required for mounting a Modesty Panel without a Cable Management Trough
- Available in 3 colors to match frameset

Model #			Weight	List
Silver	Charcoal	White		
ACC-MODMNTKIT-S	ACC-MODMNTKIT-C	ACC-MODMNTKIT-W	2	\$32







Essentia, Workrite's newest and most exciting height adjustable workcenter, is now available for use in both free standing and benching applications thanks to our patent pending dual platform foot design. Essentia features our exclusive European manufactured industrial design, an inductive touch control switch with 6 memory presets, and adjustable stretchers that provide greater flexibility for workspace design.

Essentia meets BIFMA G1-2013 standards for adjustability, exceeds BIFMA X5.5 requirements for durability, is UL Listed and Greenguard certified. It is, quite simply, one of the highest quality, value priced workcenters in the market today.



Essentia Frame Sets

Essentia Frame Set, 30-48" Wide
Essentia Frame Set, 54-72" Wide

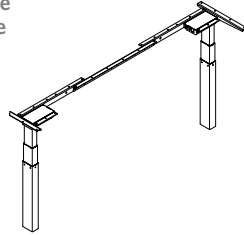

Model #			Weight	List
Silver	Charcoal	White		
ES3E30-48-S	ES3E30-48-C	ES3E30-48-W	42	\$1,101
ES3E54-72-S	ES3E54-72-C	ES3E54-72-W	48	\$1,141

Essentia Foot Kits

Essentia Benching Foot Kit, Dual Station

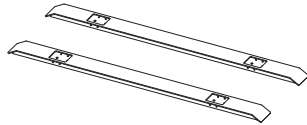

- Perfectly align 2 workstations back-to-back
- Reinforced steel construction for added stability
- Compatible with 29" deep tops only
- Sold as a pair (for 2 workstations)

Model #	Color	Weight	List
ES-BFK48-S	Silver	48	\$247
ES-BFK48-C	Charcoal	48	\$247
ES-BFK48-W	White	48	\$247

Essentia Flat Foot Kit, Single Station

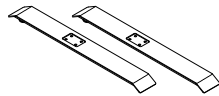

- 30" flat foot provides exceptional stability for single workstations
- Use with stand-alone tables or Side to Side single row benching applications
- Sold as a pair (for 1 workstation)

ES-FS30-S	Silver	2	\$93
ES-FS30-C	Charcoal	2	\$93
ES-FS30-W	White	2	\$93

Essentia Benching - Foot Connectors

Essentia Bench Foot Connector Kit

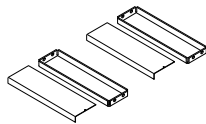

- Creates a uniform 4" gap between all workstations (Side to Side)
- Easily connect workcenters while assembled
- Magnetic decorative cover
- Sold as a pair (for 4 Back to Back workstations or 3 Side to Side workstations)

Model #	Color	Weight	List
ES-BF-CONKIT-S	Silver	6	\$51
ES-BF-CONKIT-C	Charcoal	6	\$51
ES-BF-CONKIT-W	White	6	\$51

Essentia Bench Foot Connector Kit - Adaptor

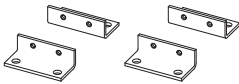

- Create single row, Side to Side benching style workstations
- Use with Essentia Flat Foot Kit and Essentia Bench Foot Connector Kit
- Sold as a set (for two Side to Side workstation)

ES-SF-CKADPT-S	Silver	1	\$35
ES-SF-CKADPT-C	Charcoal	1	\$35
ES-SF-CKADPT-W	White	1	\$35

Essentia Workcenter Controls

Essentia Standard Switch

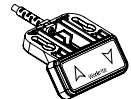

- Simple up/down button control switch
- Includes cable management & mounting hardware

Model #	Weight	List
ES-B-SWITCH	1	\$35

Essentia Programmable Switch

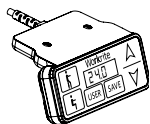

- Inductive touch control prevents accidental movement
- Three user sit & stand memory pre-sets (six total)
- Swipe to lock/unlock feature
- Programmable upper and lower height limits
- Digital height readout
- Manual up/down control buttons
- Includes cable management & mounting hardware

ES-P-SWITCH	1	\$105
-------------	---	-------

NOTE: See Workrite Pricing & Specification Guide for additional Essentia Workcenter options, parts and accessories.

Our unique, hardwired power distribution system is UL listed and replaces bulky power distribution troughs and old-fashioned panel systems by enabling you to power up to 10 workstations from one cord. Standard power cords are also available for individual workcenters.

For easy, convenient user access, choose between recessed or flush mounted power modules. Both modules feature two outlets and two USB charging ports located above the worksurface and two outlets below the worksurface.

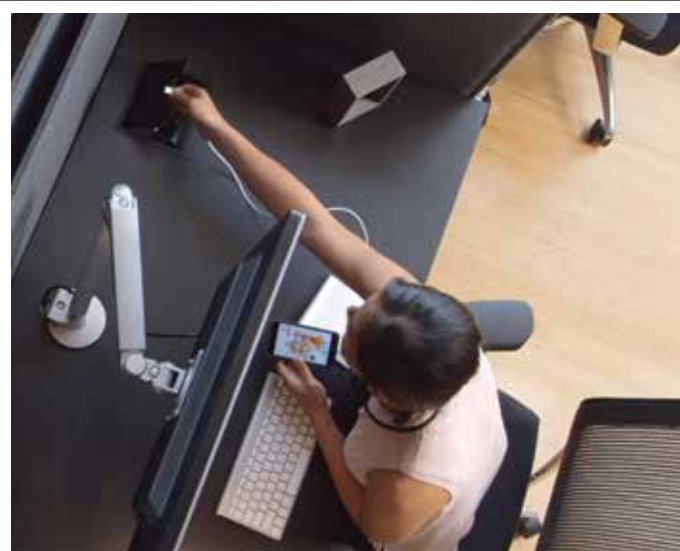

Power Distribution Modules

		Circuit	Model #	Color	Weight	List
--	--	----------------	----------------	--------------	---------------	-------------

Power Module, Circuit 1

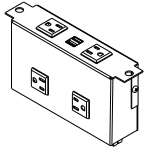

- Receives & distributes power for up to 5 workstations (5 station maximum, per power in-feed cable & 1 dedicated 20 Amp circuit)
- ETL Listed, Conforms to UL 183 Power Distribution Systems Standards
- Color coded quick connection ports to power in-feed & power distribution cables
- 4 power outlets (120 VAC, 15 Amp) – 2 above, 2 below work surface
- 2 USB charging ports (2.1 Amp for fast phone or tablet charging)
- Scratch resistant, powder coated paint

		1	ACC-PMC1-4P2U-B	Black	3	\$501
--	--	---	-----------------	-------	---	-------

Power Module, Circuit 2

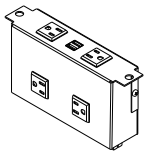

- Receives & distributes power to 5 additional workstations (10 station maximum, per power in-feed cable & 2 dedicated 20 Amp circuits)
- ETL Listed, Conforms to UL 183 Power Distribution Systems Standards
- Color coded quick connection ports to power in-feed & power distribution cables
- 4 power outlets (120 VAC, 15 Amp) – 2 above, 2 below work surface
- 2 USB charging ports (2.1 Amp for fast phone or tablet charging)
- Scratch resistant, powder coated pain

		2	ACC-PMC2-4P2U-B	Black	3	\$501
--	--	---	-----------------	-------	---	-------

Power Jumper Block



- Creates a 90 degree station-to-station jumper cable connection
- Color coded quick connection ports for power distribution cables
- Scratch resistant, powder coated paint

			ACC-PWR-JBLOCK-B	Black	2	\$209
--	--	--	------------------	-------	---	-------

Power In-feed Cables

Hardwire Power In-Feed Cable with Quick Connect

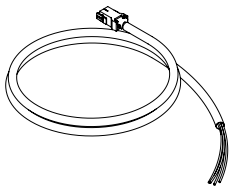

- 4 wire, 2 circuit power in-feed cable
 - Hardwired connection, to be operated on one dedicated 20 Amp circuit for up to 5 stations or two dedicated 20 Amp circuits for up to 10 stations
 - A balanced electrical circuit configuration is recommended for 6 or more stations
 - Connection to the building wiring must be done by a qualified electrician according to national state & local codes
- Color coded quick connect plug to Power Module for easy installation
- 96" flexible metal conduit cable with black mesh cover

			Model #	Color	Weight	List
			ACC-PWR-IN-HDWR-B	Black	3	\$184

Power In-feed Cables

Hardwired Power Outlet with Dual Quick Connect Power In-feed Cable

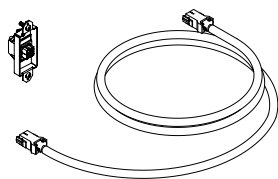

- Quick Connect power outlet
 - Fits standard electrical j-box
 - Use Decora® face plate for trim (not provided)
 - 4 wire, 2 circuit power in-feed wiring
 - Hard wired connection, to be operated on one dedicated 20 Amp circuit for up to 5 stations or two dedicated 20 Amp circuits for up to 10 stations
 - A balanced electrical circuit configuration is recommended for 6 or more stations
 - Connection to the building wiring must be done by a qualified electrician according to national state & local codes
- Quick Connect Power In-Feed Cable
 - Easy to use color coded quick connect plugs
 - 96" flexible metal conduit cable with black mesh cover

Model #	Color	Weight	List
ACC-PWR-IN-FFP-B	Black	2	\$229

Power In-feed Cable for Standard Wall Outlets

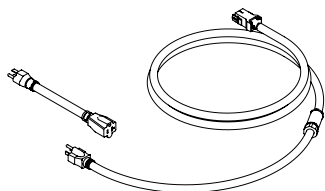

- Powers single workstation only
- 72" quick connection plug with flexible metal conduit cable and black mesh cover to flex cord with 20 Amp molded plug
- Requires 20 Amp to 15 Amp adaptor (Included)
- 80" overall length

Power Module Circuit	Model#	Color	Weight	List
1	ACC-PWR-IN-C1-SNGL-B	Black	2	\$221
2	ACC-PWR-IN-C2-SNGL-B	Black	2	\$221

Power Distribution Cables

Below Desk Cross Cables

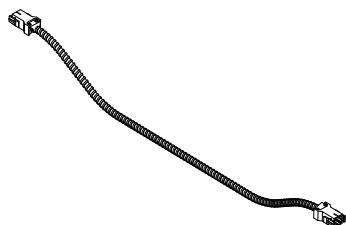

- Connects Power Module to Power Jumper Block
- Easy to use color coded quick connect plugs
- Flexible metal conduit cable
- Includes cable management clips
- Available in 3 lengths (24", 36" & 48") to match workstation sizes

Worksurface Sizes	Model #	Color	Weight	List
46"	ACC-PWR-CCBL-24	Silver	1	\$89
58"	ACC-PWR-CCBL-36	Silver	1	\$101
70"	ACC-PWR-CCBL-48	Silver	1	\$113

Side to Side Jumper Cable

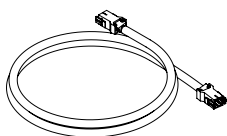

- Connects Power Jumper Block to Power Module in side to side workstations
- 50" flexible metal conduit cable with black mesh cover
- Easy to use color coded quick connect plugs

50"	ACC-PWR-JSSCBL-50-B	Black	1	\$130
-----	---------------------	-------	---	-------

Back to Back Jumper Cable

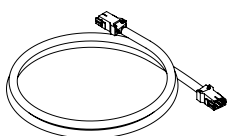

- Connects Power Jumper Block to Power Module in back to back workstations
- 54" flexible metal conduit cable with black mesh cover
- Easy to use color coded quick connect plug

54"	ACC-PWR-JBBCBL-54-B	Black	1	\$135
-----	---------------------	-------	---	-------



Accessorizing your workcenter has never been easier

Workrite's workcenter accessory program provides complete solutions for outfitting the modern workcenter. Select from a wide variety of options for use above and below the worksurface including modesty panels, privacy panels, and wire management tools, just to name a few.

Workrite's accessory products are not only compatible with our adjustable height workcenters, they can also be used with many of the most popular furniture systems and other adjustable height workstations in the market today.

Our privacy and modesty panels deliver the ideal blend of style, functionality, and modularity. Accessorize your work center with panels that not only look great, but have been proven to help reduce noise and provide the visual privacy required to maintain concentration levels and increase workplace productivity.

Below the worksurface, our high quality, powder-coated steel cable management trough features large openings and convenient side and back pass-through ports that make wire management a breeze.

Below Desk Accessories

Cable Management Trough

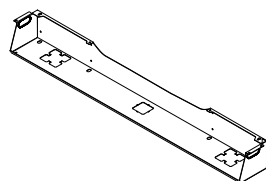

- Conceal cables and transformers in the 5.25" high by 5.5" deep cable trough
- Top cut-out allows c-clamps to be mounted to the back of the desk
- Three bottom cable pass through ports designed to use with Cable Management Chain
- Accommodates optional Laminate Modesty Panel
- Constructed using heavy duty 16 gage steel and scratch resistant powder coated paint
- Available in 3 colors to coordinate with frameset

Model #	Color	Actual		List
		Width	Weight	
ACC-CBLTRKIT-41-S	Silver	41.25"	12	\$96
ACC-CBLTRKIT-41-C	Charcoal	41.25"	12	\$96
ACC-CBLTRKIT-41-W	White	41.25"	12	\$96
ACC-CBLTRKIT-53-S	Silver	53.25"	15	\$109
ACC-CBLTRKIT-53-C	Charcoal	53.25"	15	\$109
ACC-CBLTRKIT-53-W	White	53.25"	15	\$109
ACC-CBLTRKIT-65-S	Silver	65.25"	17	\$127
ACC-CBLTRKIT-65-C	Charcoal	65.25"	17	\$127
ACC-CBLTRKIT-65-W	White	65.25"	17	\$127

Cable Manager Chain



- Manage & conceal cables, up to 2" bundle (max .75" individual cables)
- Single axis flex design neatly manages cables as workstations move
- Expand and contract lengths using quick ball and socket connections
- 32 links included for use in worksurface-to-floor or station-to-station applications
- Available in 3 colors to coordinate with frameset

ACC-PWR-CBLCHAIN-S	Silver	2	\$142
ACC-PWR-CBLCHAIN-B	Black	2	\$142
ACC-PWR-CBLCHAIN-W	White	2	\$142

Cable Chain Trough Mount Kit



- Easily attach Cable Management Chain to Cable Management Trough

ACC-PWR-CHTRMT-S	Silver	1	\$33
ACC-PWR-CHTRMT-B	Black	1	\$33
ACC-PWR-CHTRMT-W	White	1	\$33

Cable Chain Desk/ Floor Mount Kit

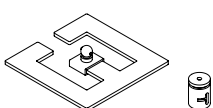

- Weighted floor plate with non-skid feet
- Desk Mounting Kit for Non-Cable Management Trough installation applications
- Uses quick ball & socket connections for easy assembly

ACC-PWR-CHFLRMT-S	Silver	1	\$33
ACC-PWR-CHFLRMT-B	Black	1	\$33
ACC-PWR-CHFLRMT-W	White	1	\$33

Above Desk Accessories

Tool Bar

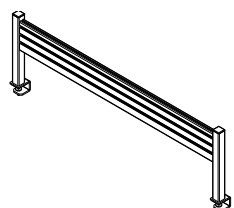

- Three channel aluminum Tool Bar allows users to mount monitor arms, lights and organizational accessories 7.25"-13" above the work surface
- Holds up to 75lbs
- Two quick mount aluminum supports installs on worksurfaces .5" to 1.25" thick

Worksurface Size	Model #		Weight	List
	Silver	Charcoal		
46"	980-46-S	980-46-C	15	\$328
58"	980-58-S	980-58-C	17	\$353
70"	980-70-S	980-70-C	19	\$364

Privacy Panel

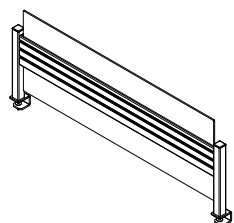

- Add visual privacy and function to your workstation
- 18.25" high panel features 5" frosted acrylic panels above and below the structural tool bar
- Three channel aluminum Tool Bar allows users to mount monitor arms, lights and organizational accessories 7.25"-13" above the work surface
- Holds up to 75lbs
- Two quick mount aluminum supports installs on worksurfaces .5" to 1.25" thick

Worksurface Size	Model #		Weight	List
	Silver	Charcoal		
46"	981-46-S	981-46-C	19	\$532
58"	981-58-S	981-58-C	23	\$750
70"	981-70-S	981-70-C	26	\$771



TRANQUILITY PANEL SYSTEMS

Our Tranquility panels add the perfect finishing touch to any desk or benching system. Made from 100% recycled and recyclable materials, Tranquility panels not only look great they help reduce noise and provide the visual privacy required to maintain concentration levels and increase productivity.

Tranquility Panel Systems

PET Felt

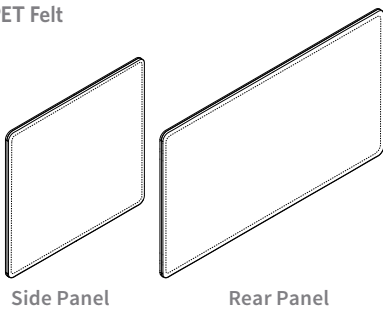

- Reduce office noise with Tranquility acoustic panels
 - ASTM C423-09a Rated Panels: 0.55 NRC (Noise Reduction Coefficient)
- Panels feature a soft tackable surface for workstation personalization
- Create above & below desk privacy with these 26" high panels (maximum 18" above with 8" below the worksurface)
- 100% Recycled PET felt
- Available in 12 color options

Worksurface Size	Model # (X's represent color choice)	Weight	List
Side Panel			
29" deep	TRQ-PET-28X26-XXXX	10	\$499
Rear Panels			
46" wide	TRQ-PET-455X26-XXXX	17	\$699
58" wide	TRQ-PET-575X26-XXXX	21	\$799
70" wide	TRQ-PET-695X26-XXXX	25	\$899

Wool Blend Fabric

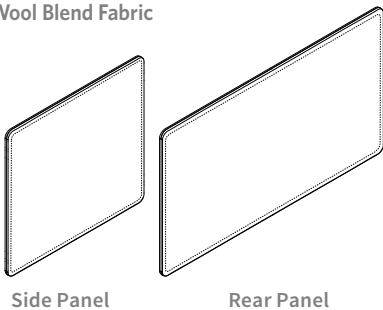

- Reduce office noise with Tranquility acoustic panels
 - ASTM C423-09a Rated Panels: 0.6 NRC (Noise Reduction Coefficient)
- Panels feature a soft tackable surface for workstation personalization
- Create above & below desk privacy with these 26" high panels (maximum 18" above with 8" below the worksurface)
- 100% Recycled PET felt and wool blend fabric
- Available in 35 color options

Worksurface Size	Model # (X's represent color choice)	Weight	List
Side Panel			
29" deep	TRQ-WOOL-28X26-XXXXX	11	\$699
Rear Panels			
46" wide	TRQ-WOOL-455X26-XXXXX	18	\$999
58" wide	TRQ-WOOL-575X26-XXXXX	22	\$1,099
70" wide	TRQ-WOOL-695X26-XXXXX	27	\$1,199

Tranquility - Mounting Brackets

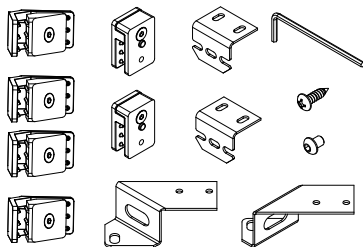

- Attach 3 panels (one rear and two side panels) to your work surface
- Clamp mount design provides flexibility and will not damage panels when properly installed
- Available in brushed aluminum finish

TRQ-MNT-DESK3PNL-BA	3	\$119
---------------------	---	-------

Note: Tranquility available January 15, 2017

TRANQUILITY - PET FELT



TRANQUILITY - WOOL BLEND FABRIC







Whichever combination of products you choose, Workrite helps to create the ultimate modern workplace designed to provide years of efficiency, flexibility and style for your ever-changing needs.

Workrite Ergonomics.

A BETTER WAY
TO WORK.



Workrite

ergonomics®

2277 Pine View Way, Suite 100
Petaluma, CA 94954-5688
Phone 800.959.9675
Fax 800.930.8989
www.workriteergo.com

© 2016 Workrite Ergonomics
All rights reserved.

1400536 Rev A