



IRMA SIDE CHAIR ASSEMBLY



A
M8 X 50
4 PCS



B
1 PC

STEP 01

SECURE WOOD LEG FRAME
TO THE SEAT CUSHION.
SECURE WITH 4 A SCREWS.

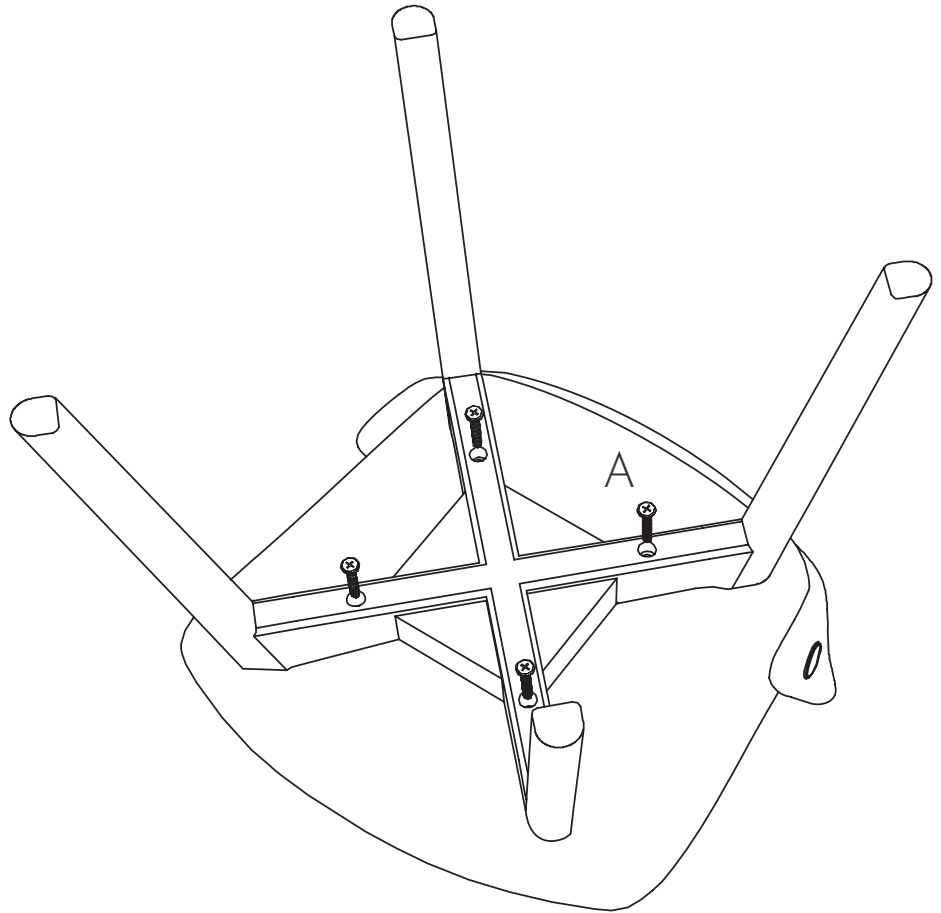



IRMA Plastic Side Chair with Metal Base ASSEMBLY



A
M4 X 10
2 PCS



B
M6 X 10
6 PCS



C
6 PCS

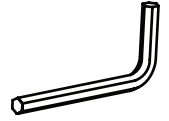

D
4MM/2.5MM
1 PC EACH

STEP 01

ATTACH BACKREST TO SEAT,
SECURE WITH 2 A SCREWS,
ONE ON EACH SIDE.

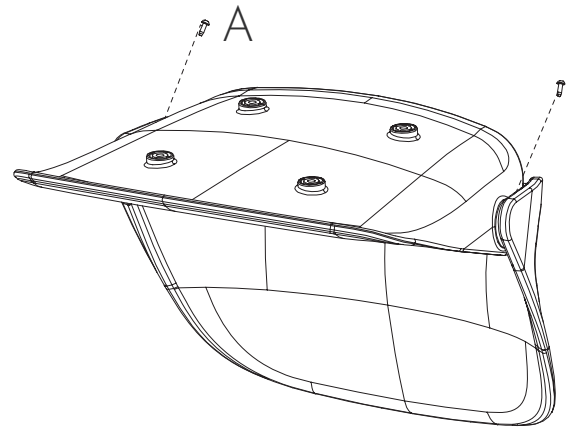

STEP 02

ATTACH CONNECTING LEVEL TO SEAT
FRAME, SECURE TO FRAME WITH 2 B
SCREWS AND 2 C WASHERS.

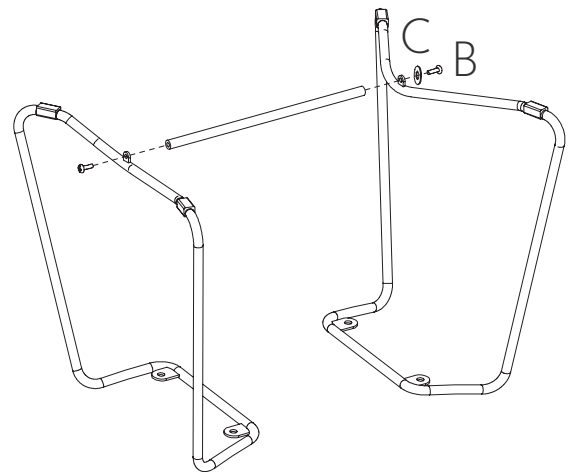



IRMA Plastic Side Chair with Metal Base ASSEMBLY

STEP 03

ATTACH ASSEMBLED SEAT FRAME
TO SEAT BOTTOM, SECURE 4 B
SCREWS AND 4 C WASHERS.

MAKE SURE ALL SCREWS ARE
SECURED TIGHTLY.

